



Pneumatic Rotary Actuator

Series RA

Catalogue 9127006882GB-ul



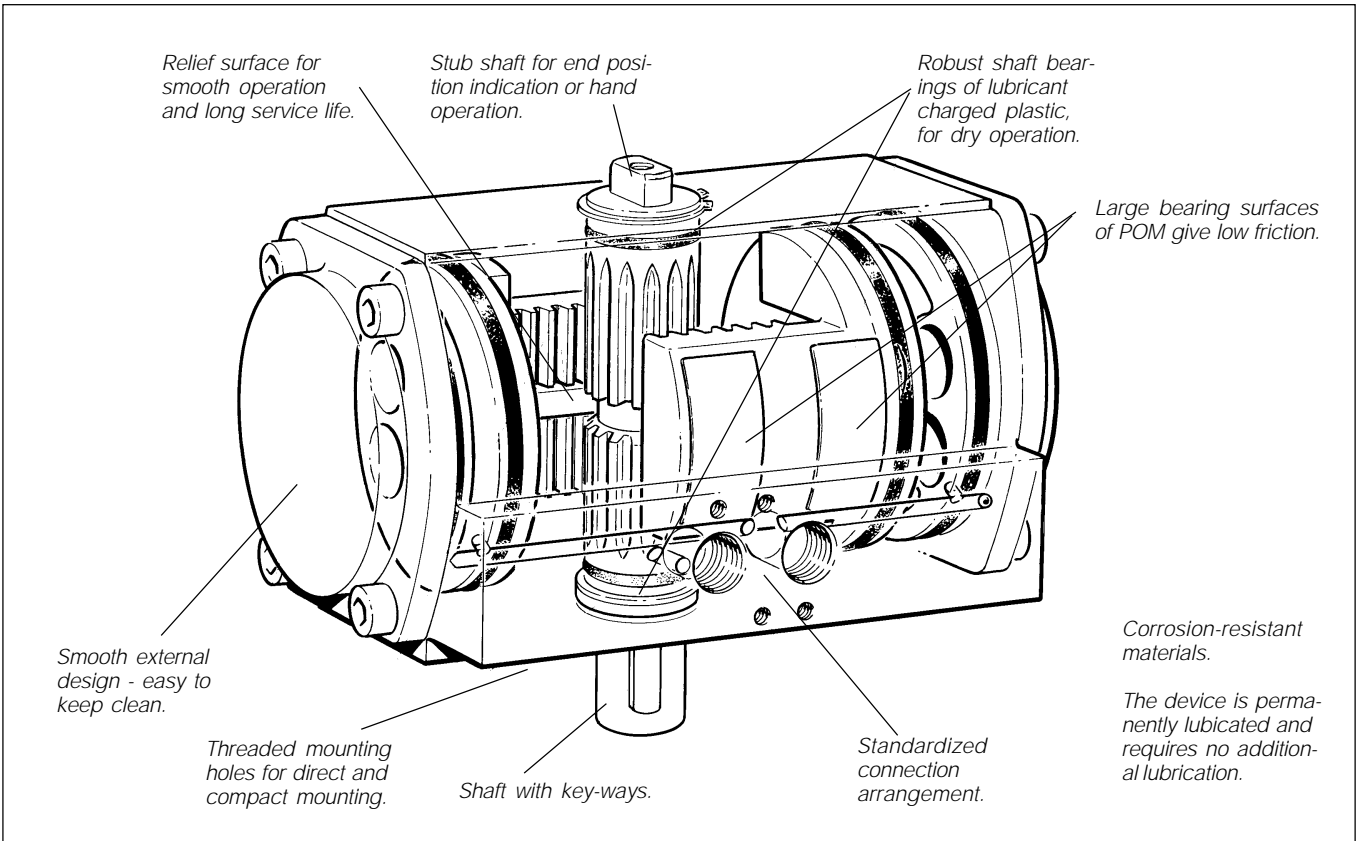

Pneumatic rotary actuator RA

The RA is a double-acting rotary actuator of very compact design. It has a high torque and small installation dimensions. The actuator has double pistons, which transmit the turning moment to the output shaft. The toothed piston rods act on the output shaft in a rack-and-pinion type arrangement. Each piston and toothed rod is of integral construction. The rack-and-pinion type arrangement gives an even turning moment throughout the rotation movement.

The drive shaft is robustly supported in bushings of self-lubricating plastic. There are key-ways on the output end of the shaft, while the opposite end of the shaft has a stub that can be used to accommodate end-position indication, or to facilitate hand operation of the actuator. The turning limits of the rotary actuator should be determined by external stop lugs, in order to protect the unit from the effects of excessive load inertia.

Compressed air is fed into the piston chambers via a connection plate and drilled galleries in the central part and end covers. The connection plate is fitted to a standardized connection arrangement on one of the long sides of the unit. This means that the end covers are completely smooth, without any protruding parts.

The RA rotary actuator has a cylinder block of natural anodized aluminium, with end covers of black anodized aluminium. The unit is available in 5 different sizes, covering a turning-moment range of 20 to 200 Nm. As standard, all sizes are available with a turning angle of either 90° or 180°.

Technical data

Working medium dry, filtered compressed air
 Working pressure max. 1000 kPa (10 bar)
 Working temperature -20 °C to +80 °C

Ordering information for RA

Designation	Angle
RA2-90	90°
RA2-180	180°
RA4-90	90°
RA4-180	180°
RA8-90	90°
RA8-180	180°
RA12-90	90°
RA12-180	180°
RA20-90	90°
RA20-180	180°

Material specification

Cylinder block/end covers	Anodized aluminium, natural/black
Pistons	Aluminium
Relief surface bars	Stainless steel
Shaft	Zinc-plated steel
End cover screws	Zinc-plated steel
Seals	Nitrile rubber, NRB
Piston bearings	POM
Shaft bearings	Polyethene MOS2



Important
 Before attempting any external or internal work on the rotary actuator or any connected components, make sure the rotary actuator is vented and disconnect the air supply in order to ensure isolation of the air supply.

Note
Air quality is essential for maximum cylinder service life (see ISO 8573).

Note
All technical data in this catalogue is typical data only.

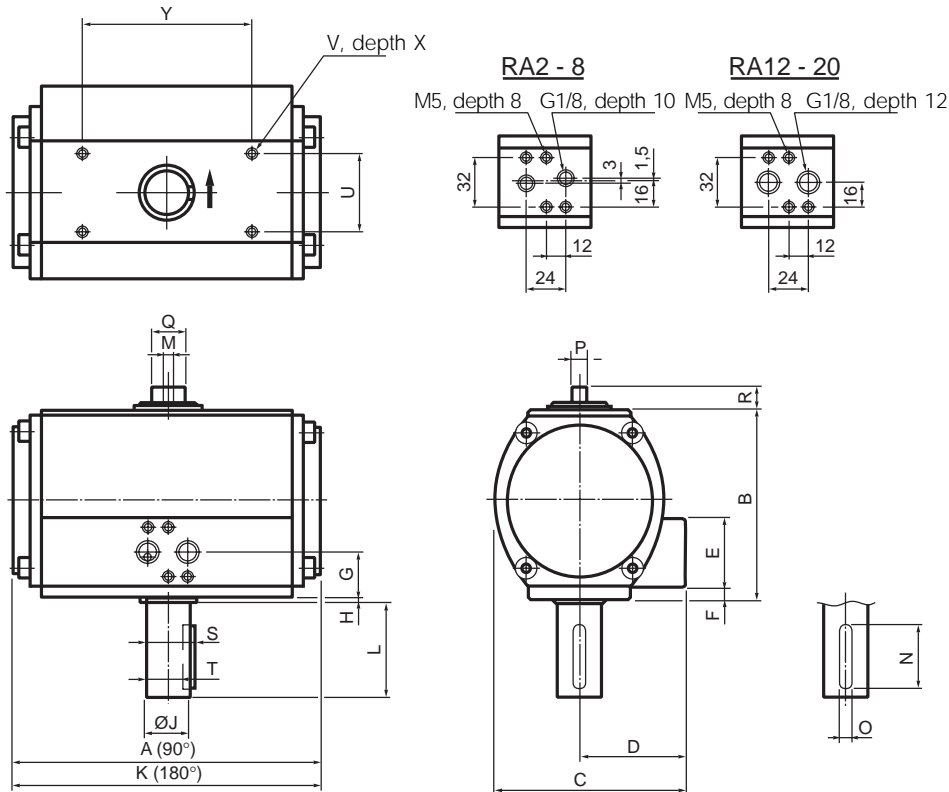

Dimensions

Designation	A	B	C	D	E	F	G	H	ØJh8	K	L	M	N	O	P
RA2	114,5	73,0	75,5	43,5	41	-	20,5	4	14	169	30	M6	19	5	7,5
RA4	133,0	90,5	87,5	47,5	41	-	20,5	4	19	215	40	M6	31	6	7,5
RA8	162,0	109,0	105,0	57,0	42	7,5	28,5	4	19	245	40	M8	31	6	11,5
RA12	194,0	118,5	121,0	67,0	43	8,0	29,5	5	28	295	60	M8	48	8	11,5
RA20	218,0	140,5	136,5	72,0	43	8,0	29,5	5	28	337	60	M8	48	8	11,5

Designation	Q	R	S	T	U	V	X	Y
RA2	13	10,0	16,0	11,0	32	M5	8	50
RA4	15	11,0	21,5	15,5	32	M5	8	73
RA8	17	13,5	21,5	15,5	40	M6	10	90
RA12	20	15,0	31,0	24,0	49	M6	10	107
RA20	25	15,0	31,0	24,0	60	M6	10	120

Table of moments at 6 bar

Designation	Moment in Nm
RA2	22,8
RA4	45,0
RA8	81,7
RA12	134,0
RA20	224,0

Spare parts

Designation	Ordering No.
Mounting plate for VGD15	9127 3864-01
seal kits/spare kits:	
RA-2-SS	9121 6799-20
RA-4-SS	9121 6799-21
RA-8-SS	9121 6799-22
RA-12-SS	9121 6799-23
RA-20-SS	9121 6799-24

Air consumption

Free air consumption in NI per double stroke at 600 kPa (6 bar).

Rotary actuator, type/ Turning angle	RA2	RA4	RA8	RA12	RA20
RA/90°	1,8	3,2	5,9	7,8	14,9
RA/180°	3,6	6,4	11,8	15,6	30

Variants available on request:

- Single-acting rotary actuator with spring return for 90°
- Non-standard turning angle
- Adjustable end position
- Other surface treatments