



Pneumatic cylinders

Series P1D

According to ISO, VDMA and AFNOR

Catalogue 9127007812GB-ul



Contents	page
ISO cylinder family, P1D	3
P1D Standard	4
P1D Clean	6
P1D Flexible Porting	8
P1D Tie-Rod	10
Design variants	11
Main data: P1D	13
Cylinder forces	13
Standard stroke	14
Material specification	15
Cushioning characteristics	15
Guide for selecting suitable tubing	16
Introduction to the ATEX directive	18
Dimensions P1D Standard	22
Dimensions P1D Clean, P1D Tie-Rod, P1D Flexible Porting	23
Order key P1D Standard and P1D Tie rod	24
Order code standard strokes P1D Standard	25
Order key for cylinders with factory fitted accessories	26-34
Order code standard strokes P1D Clean	35-37
Order key P1D Flexible Porting	38
Order code standard strokes P1D Flexible Porting	39
Order key P1D Clean and P1D Flexible Porting combined	40
P1D complete working unit with factory fitted valve	41-43
P1D cylinder with piston rod locking	44-47
P1D with rod guidance modules	48-51
Cylinder mountings	52-56
Piston rod mountings	57-58
Combinations, mountings	59-60
Accessories	61
Combinations, cylinders	62
Electronic sensors and Reed sensors	63-64
Connecting cables and cable connectors	65-66
Connecting cables with one connector+	66
Connection block Valvetronic 110	67
P1D Seal kits	68
Complete working units – ready for installation	69
Main order code P1D	70-74



Important!

Before carrying out service activities, make sure the cylinder is vented. Before disassembling the cylinder, disconnect the primary air hose to ensure that the air supply is interrupted.



NOTE!

All technical data in the catalogue are typical values.
The air quality is a major factor in the service life of the cylinder, see ISO 8573-1.



WARNING

FAILURE OR IMPROPER SELECTION OR IMPROPER USE OF THE PRODUCTS AND/OR SYSTEMS DESCRIBED HEREIN OR RELATED ITEMS CAN CAUSE DEATH, PERSONAL INJURY AND PROPERTY DAMAGE.

This document and other information from Parker Hannifin Corporation, its subsidiaries and authorized distributors provide product and/or system options for further investigation by users having technical expertise. It is important that you analyze all aspects of your application and review the information concerning the product or system in the current product catalog. Due to the variety of operating conditions and applications for these products or systems, the user, through its own analysis and testing, is solely responsible for making the final selection of the products and systems and assuring that all performance, safety and warning requirements of the application are met. The products described herein, including without limitation, product features, specifications, designs, availability and pricing, are subject to change by Parker Hannifin Corporation and its subsidiaries at any time without notice.

SALE CONDITIONS

The items described in this document are available for sale by Parker Hannifin Corporation, its subsidiaries or its authorized distributors. Any sale contract entered into by Parker will be governed by the provisions stated in Parker's standard terms and conditions of sale (copy available upon request).



ISO cylinder family, P1D

A completely new cylinder range from the ground up, with major investment in research, material and technology, demands long experience and major resources. When we developed our P1D cylinder range, we started from scratch, but not really. Decades of research and learning about what our customers really need world-wide has given us a very stable foundation to start from.

P1D is a cylinder design of the highest possible quality, every detail has been thought through, without making any compromises. It has a large number of innovations which could only be achieved by using the best possible materials and methods. The result is a complete family of ISO/VDMA cylinders, of which we are very proud.

P1D is a high technology cylinder design for just about every conceivable application, both simple and highly complex.

The same high technology platform is used for three main versions:

- **P1D Standard** – the universal, general purpose cylinder with high performance and long life.
- **P1D Clean** – the new product level for ISO/VDMA cylinders of clean design with a system of integrated, adjustable sensors (patent applied for), for stringent hygiene demands.
- **P1D Flexible Porting** – the innovative design which saves space and reduces dimensions by allowing connections to be made in the front or rear end of the cylinder.

Let us present Series P1D more in detail in the following pages.

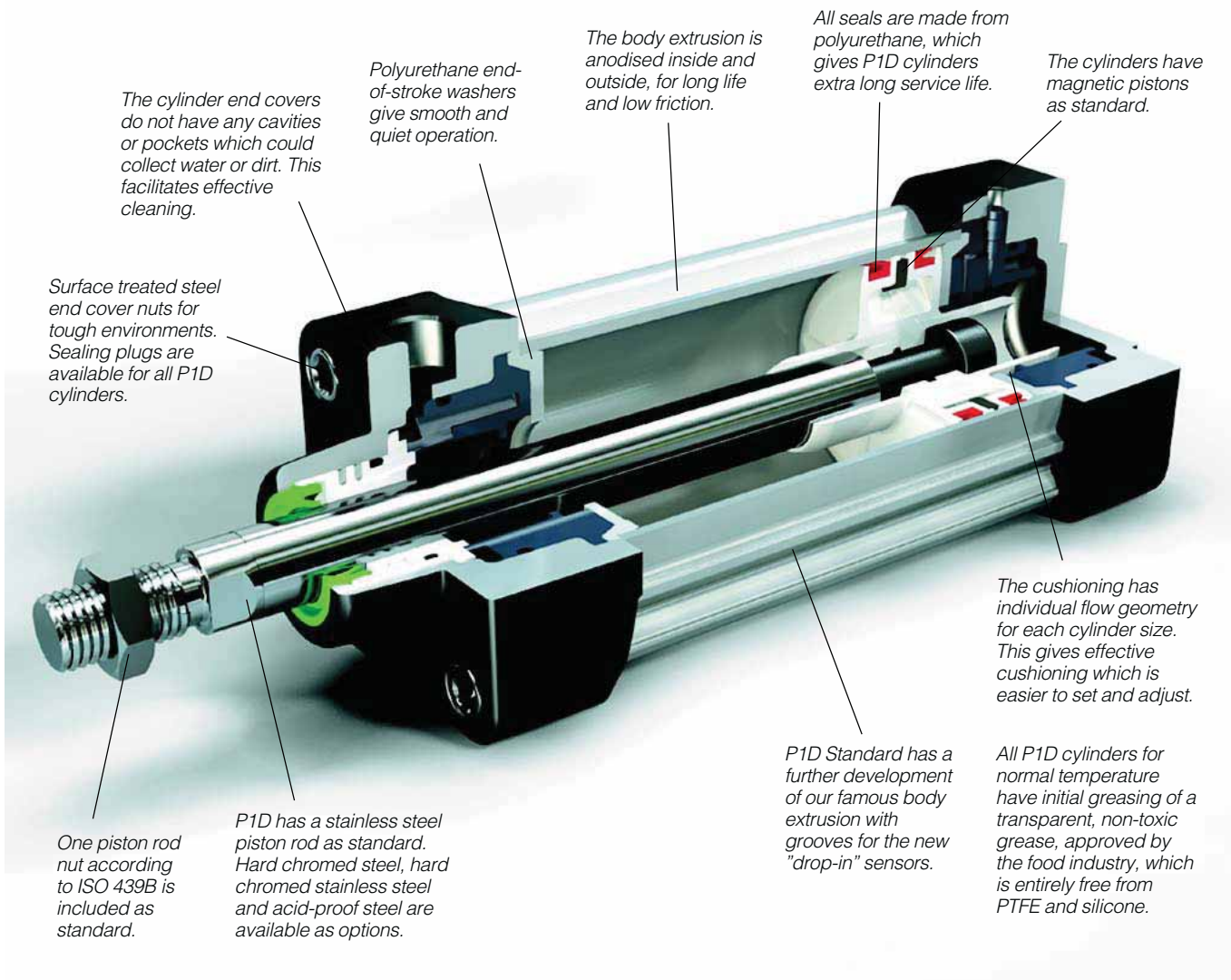

P1D Standard

The innovative P1D is a future-proof generation of ISO/VDMA cylinders. The cylinders are double-acting, with a new design of air cushioning. The light, stiff body extrusion has sensor grooves for simple and protected sensor installation.

Installation dimensions according to international standards

The new P1D complies with the current ISO 6431, ISO 15552, VDMA 24562 and AFNOR installation dimension standards. For customer reassurance worldwide.

High technology design

The best materials, manufacturing methods and design of every detail have been carefully tested, to give the best possible product. The internal components are made of high strength plastics, for quiet operation and long service life. The aluminium end caps and the torsionally stiff aluminium body extrusion make the cylinder robust and suitable for a wide range of applications.

High quality

The P1D has been developed with quality in all phases – requirement specification, design, planning, purchasing, production, distribution and service. We have been certified under the ISO 9001 QA standard for the past ten years. Quality in all our products and services is our watchword.

Even more functions and variants

The P1D is available with all the usual optional designs, such as: Through piston rod, high and low temperature, hydraulic operation, extended piston rod etc.

A new special variant is the unique self-lubricating HDPE scraper ring and piston rod seal, specially designed for operation with a completely dry piston rod (i.e. applications where the film of grease on the piston rod is regularly washed off).

Complete accessory programme

P1D offers a complete ISO, VDMA and AFNOR compatible accessory programme, with a wide range of piston rod and cylinder mountings for both pivoted and fixed operation. Several of these types of mountings are available in stainless steel. The new "drop-in" sensors are available with both reed and electronic operation, with a wide choice of connector types and cable lengths.



New, mechanically protected sensor technology

The body extrusion has recessed sensor grooves on three sides of the cylinder. The new sensors are of the "drop-in" type, and are quickly and easily installed in the T-groove from the side. Both the cable and the sensor are protected in the groove. Choose a sensor with 3 or 10 m cable, 8 mm connector or the new M12 connector.



Optimised cushioning

Thanks to the plastic inserts in the end covers, each cylinder bore has been given individual flow geometry. This provides optimised cushioning, which is quicker and easier to set and adjust.



Smooth, quiet operation and long service life

All seals and end-of-stroke washers are made from polyurethane (PUR), the bearings and piston are made from proven engineering plastics with excellent bearing properties and all cylinders are greased at the factory with a transparent, foodstuffs-approved grease. Altogether this gives the P1D very long service life and smooth, quiet operation.





P1D Clean

P1D Clean is a new version in our ISO cylinder system, completely designed for the foodstuffs industry. Many years' experience of the stringent requirements for hygiene, choice of material and corrosion resistance, from a wide spectrum of foodstuffs applications have guided the development of this cylinder version. Great emphasis has been put on the external design of the cylinder, choice of materials and corrosion protection.

Main dimensions according to international standards

All the main dimensions of the P1D Clean comply with ISO 6431, ISO 15552, VDMA 24562 and AFNOR standards. The exception is the somewhat larger footprint of the end covers and envelope of the body extrusion, due to the so-called positive geometry (hygienic, convex, easy-to-clean geometry) of the cushioning adjustment screw and the components in the integrated sensor system.

Common, high technology design platform

The P1D Clean has the same technical platform as the P1D Standard. The best materials, including the polyurethane (PUR) seals, manufacturing methods and the careful attention to detail design give the P1D Clean smooth, quiet operation and long service life.

Convex shape for optimum hygiene

P1D Clean has a convex body extrusion, which makes the cylinders easy to keep clean. Irrespective of installation position, fluids run off the body extrusion surfaces.

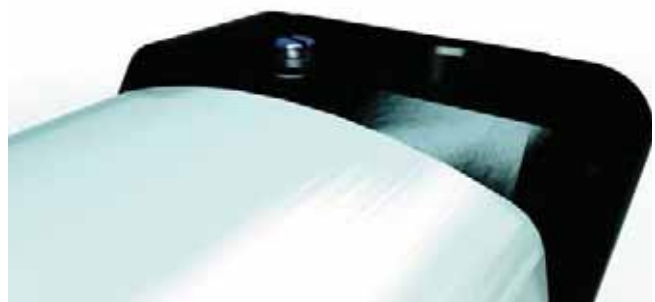

Cushioning screw with positive geometry

To offer the best hygiene properties, the projecting cushioning screw, is sealed with rubber seal against the end cover. This eliminates dirt-collecting cavities and gives the best hygiene, since it is so easy to clean.



Sealing plugs

Four plastic sealing plugs are supplied with every P1D Clean cylinder. These are installed in the end cover screws which are not used for the cylinder installation. To ensure the sealing function, the plugs can be used only once i.e. they can not be re-used. When installed in the end cover screws, they should be tapped lightly with a hammer to securely fix.



Patent applied system for integrated standard sensors

The P1D Clean cylinder has a system of sensors, which are fully integrated into the body extrusion, to give the cylinders a clean external design. Up to four sensors chosen from the range of P1D standard sensors, reed or electronic operation, can be mounted in two dedicated grooves beneath a transparent, sealed moulding. Tightening the stop screw onto the cam shaft, will lock each sensor in the desired position, with great force. The sensor LEDs are always fully visible, which facilitates commissioning, adjustment and trouble-shooting. The entire sensor system has a hose-proof design, equivalent to IP65. P1D Clean can be ordered with factory-fitted sensors in the end positions, which can then easily be moved to any other position along the entire stroke.



Up to four integral sensors

Cylinders for two integral sensors have two undivided camshafts along the entire stroke. Free choice of cable exit, front or rear. There is also a version with divided camshafts for up to four sensors, which are installed two from each end cover, with cable exit front and rear.

Simple sensor adjustment

The sensors are mounted into their grooves through the opening in a transparent, sealed cover. The sensor cables have strain relief and are sealed.

The sensor position is easily adjusted by undoing a set screw and using the cable to move the sensor to the desired position.

Once the sensor has been locked in its new position, the protective cover is installed again.





P1D Flexible Porting

Progress leads to smaller components and machinery. In harmony with this trend, and complying with the main dimension requirements in ISO 6431, we have developed P1D Flexible Porting, which offers new, smarter design solutions. Since one end of the cylinder can be placed in restricted, unused spaces, without needing any connections, the space in the application can be used more efficiently, or made more compact.

Main dimensions according to international standards

Apart from the projecting connections on sizes Ø32–63 mm P1D Flexible Porting complies with ISO 6431, ISO 15552, VDMA 24562 and AFNOR standards.

Common, high technology design platform

P1D Flexible Porting has the same high technology level as P1D Standard and P1D Clean. The future-proof design gives P1D Flexible Porting high performance and long service life.

Body extrusion with integrated air channels

P1D Flexible Porting has the same body extrusion as the P1D Clean cylinder. Since the air is led through channels built into the body extrusion, both connections can be made to either end of the cylinder. The flow capacity of the air channels is big enough not to restrict the cylinder speed in all normal applications.



Straight or elbow push-in fittings for Ø32-63 mm

For cylinder bore Ø32-63 mm, one connection is located on the body extrusion. The connector from the Moduflex valve range is used for this connection. A matching Prestolok 2 (plastic) fitting is used for the connection at the end cover. Choose between straight or elbow fittings. The other end has a plug installed in the unused cylinder port.

**Threaded connections for Ø80-125 mm**

Cylinder bore Ø80-125 mm have two threaded connections located in either end cover. The other end has plugs in the cylinder ports. These plugs can be moved to the other end to suit the application.

**Mechanically protected "drop-in" sensors**

The body extrusion, which is common to all P1D Clean and P1D Flexible Porting cylinders, has recessed sensor grooves in the side opening. The geometry has at the same time been designed for "normal" mechanical sensor installation (similar to P1D Standard) and for the built-in sensor system (P1D Clean). Use standard sensors in the usual way.

**Combine with P1D Clean**

For compact applications with stringent hygiene requirements, P1D Clean can be combined with Flexible Porting. This cylinder version complies with many different requirements and offers new opportunities for creating effective application solutions.





P1D Tie-Rod

The P1D is available in a tie-rod version, based on the same high level technology. This future-proof cylinder is the perfect choice wherever a tie-rod cylinder is needed.

Installation dimensions to international standard

The P1D Tie-Rod complies with ISO 6431, ISO 15552, VDMA 24562 and AFNOR installation dimension standards. For customer reassurance world-wide.

Smooth, quiet operation and long service life

All seals and end-of-stroke washers are made from polyurethane (PUR), the bearings and piston are made from proven engineering plastics with excellent bearing properties and the initial greasing at the factory with a transparent, foodstuffs-approved grease. Altogether this gives the P1D very long service life and gentle, quiet operation.

Optimised cushioning

Thanks to the plastic inserts in the end covers, each cylinder bore has been given an individual flow geometry. This gives an optimised cushioning, which is quicker and easier to set and adjust.

Complete accessory programme

P1D offers a complete ISO, VDMA and AFNOR compatible accessory programme, with a wide range of piston rod and cylinder mountings for both pivoted and fixed operation.

"Drop-in" sensor

The P1D Tie-Rod uses "drop-in" P1D sensors. An ingenious multi-jointed adapter fixes the sensors in any chosen position along the stroke.

Design variants for P1D Standard, P1D Clean, P1D Flexible porting and P1D Tie-Rod

Using P1D cylinders as a platform, a number of different designs can be produced to suit differing requirements. Please refer to the order key on pages 24 - 25 for the designation of each variant.

P1D complete working unit

P1D Standard can be ordered with a factory-fitted valve and piping. The valve series is the robust and compact Viking series. Of course, the entire range of P1D accessories can also be used for the P1D with built-in valve, and cylinders can be ordered with factory-fitted accessories and sensors. For more information, see page 41.



P1D cylinder with piston rod locking

The P1D cylinder is available in a version with piston rod locking, allowing the piston rod to be locked in any position. The lock unit, of the air/spring actuated type, is integrated in the front end piece of the cylinder. The lock unit can be used for braking as well as locking. With no signal pressure, the full force of the lock is applied to the piston rod, and the lock is released at 4 bar signal pressure. Lock units are available for P1D Standard (P1D-L) and P1D Clean (P1D-D) in dimensions Ø32-125 mm. P1D Standard can be ordered with a lock unit and a built-in valve (P1D-4).

For more information, see page 44

P1D-L



P1D-D



Alternative piston rod materials

All P1D cylinders in all bores, Ø32-125 mm, can be ordered with the following piston rod materials:

- Steel, hard chromed
- Stainless steel, roller polished (standard)
- Acid-proof steel, roller polished
- Stainless steel, hard chromed

Through piston rod

All P1D cylinders in all bores, Ø32-125 mm, are available with a through rod. Cylinders with a through rod can take higher side forces thanks to the double support for the piston rod. In addition, this design makes it easier to install external position sensors.



Design variants for P1D Standard, P1D Clean, P1D Flexible porting and P1D Tie-Rod

Operation with dry piston rod

In many applications, primarily in the foodstuffs industry, the cylinders are cleaned frequently. This means that the film of grease on the piston rod is washed off, which puts special demands on the materials and the design of the piston rod seal system (scraper ring and piston rod seal). A piston rod seal system specially designed for dry rod operation is available as options for this type of application, for all bores of P1D cylinders. The system has a specially designed L-shaped seal and the material is self-lubricating, high molecular weight plastics (HDPE) – the same system as in our previous P1C cylinders, with proven function.



Low and high ambient temperature

For all bores, Ø32-125 mm, the P1D can be supplied in special high ambient temperature and low ambient temperature versions. The cylinders have seal systems, materials and grease for their particular temperature ranges. The high temperature version does not have magnetic piston (no function at high temperatures). The low temperature cylinders do have magnetic piston, but remember that most sensors are specified to – 25 °C (no function below this temperature). Ambient temperature ranges:

- Low temperature: -40 °C to +40 °C
- High temperature: -10 °C to +150 °C, peaks up to +200 °C

Low pressure hydraulics

The P1D in bores Ø32 - 125 mm can be supplied with special seals for operation with low pressure hydraulics up to 10 bar. Temperature range -20 °C to +80°C.



3 and 4 position cylinders

By installing two cylinders with the same or different stroke, it is possible to build a working unit with three or four positions. This type of unit is available as factory-fitted P1D tie-rod cylinders (P1D-T) in all bores, Ø32-125 mm. Other P1D cylinders can be flange mounted back-to-back with a special mounting (see pages 49 and 56).



Tandem version

The P1D is also available as a tandem cylinder, i.e. two cylinders connected in series. This cylinder unit has almost twice the force, which is a great advantage in restricted spaces. Tandem cylinders are available as tie-rod cylinders, P1D-T, in all bores Ø32-125 mm.



Cylinder forces, double acting variants

Cyl. bore/ pist. rod mm	Stroke	Pistonarea cm ²	Max theoretical force in N (bar)										
			1,0	2,0	3,0	4,0	5,0	6,0	7,0	8,0	9,0	10,0	
32/12	+	8,0	80	161	241	322	402	483	563	643	724	804	
	-	6,9	69	138	207	276	346	415	484	553	622	691	
40/16	+	12,6	126	251	377	503	628	754	880	1005	1131	1257	
	-	10,6	106	212	318	424	530	636	742	848	954	1060	
50/20	+	19,6	196	393	589	785	982	1178	1374	1571	1767	1963	
	-	16,5	165	330	495	660	825	990	1155	1319	1484	1649	
63/20	+	31,2	312	623	935	1247	1559	1870	2182	2494	2806	3117	
	-	28,0	280	561	841	1121	1402	1682	1962	2242	2523	2803	
80/25	+	50,3	503	1005	1508	2011	2513	3016	3519	4021	4524	5027	
	-	45,4	454	907	1361	1814	2268	2721	3175	3629	4082	4536	
100/25	+	78,5	785	1571	2356	3142	3927	4712	5498	6283	7069	7854	
	-	73,6	736	1473	2209	2945	3682	4418	5154	5890	6627	7363	
125/32	+	122,7	1227	2454	3682	4909	6136	7363	8590	9817	11045	12272	
	-	114,7	1147	2294	3440	4587	5734	6881	8027	9174	10321	11468	

+ = Outward stroke
- = Return stroke

Note!
Select a theoretical force 50-100%
larger than the force required

Main data: P1D

Cylinder designation	Cylinder bore area		Piston rod dia.	Piston rod area	thread	Cushioning length	Air con- sump- tion ²⁾	Connection thread	Flexible Porting tubing dimension Push-in mm
	mm	cm ²							
P1D-•032••-XXXX ¹⁾	32	8,0	12	1,1	M10x1,25	17	0,105	G1/8	4 or 6
P1D-•040••-XXXX ¹⁾	40	12,6	16	2,0	M12x1,25	19	0,162	G1/4	4 or 6
P1D-•050••-XXXX ¹⁾	50	19,6	20	3,1	M16x1,5	20	0,253	G1/4	8 or 10
P1D-•063••-XXXX ¹⁾	63	31,2	20	3,1	M16x1,5	23	0,414	G3/8	8 or 10
P1D-•080••-XXXX ¹⁾	80	50,3	25	4,9	M20x1,5	23	0,669	G3/8	-
P1D-•100••-XXXX ¹⁾	100	78,5	25	4,9	M20x1,5	27	1,043	G1/2	-
P1D-•125••-XXXX ¹⁾	125	122,7	32	8,0	M27x2	30	1,662	G1/2	-

Total mass including moving parts

Cylinder designation	Total mass (kg) at 0 mm stroke			Supplement mass (kg) for rod locking All variants	Total mass (kg) Supplement per 10 mm stroke		
	Standard	Tie-Rod	Clean/Flex		Standard	Tie-Rod	Clean/Flex
P1D-•032••-X	0,55	0,54	0,60	0,31	0,023	0,022	0,047
P1D-•040••-X	0,80	0,79	0,88	0,44	0,033	0,030	0,063
P1D-•050••-X	1,20	1,20	1,32	0,61	0,048	0,048	0,094
P1D-•063••-X	1,73	1,73	1,86	1,25	0,051	0,051	0,101
P1D-•080••-X	2,45	2,47	2,63	2,45	0,075	0,079	0,142
P1D-•100••-X	4,00	4,00	4,22	3,72	0,084	0,084	0,168
P1D-•125••-X	6,87	6,73	7,01	6,07	0,138	0,129	0,248

Mass moving parts only (for cushioning calculation)

Cylinder designation	Mass moving parts(kg)	
	at 0 mm stroke All variants	Supplement per 10 mm stroke All variants
P1D-•032••-X	0,13	0,009
P1D-•040••-X	0,24	0,016
P1D-•050••-X	0,42	0,025
P1D-•063••-X	0,50	0,025
P1D-•080••-X	0,90	0,039
P1D-•100••-X	1,10	0,039
P1D-•125••-X	2,34	0,063

1) Stroke

2) Free air consumption per 10 mm stroke for a double stroke at 6 bar

Standard stroke

Standard strokes for all P1D cylinders comply with ISO 4393.

Special strokes up to 2800 mm.

Minimum stroke for P1D Clean is 25 mm with 0-2 sensors and 100 mm with 3-4 sensors.

Order no XXXX = Stroke	Cylinder bore (mm)	● = Standard stroke (mm)										■ = Stroke to special order							
		25	50	80	100	125	160	200	250	320	400	500	600	700	800	900	2800		
Double acting																			
P1D-S032MS-XXXX	32	●	●	●	●	●	●	●	●	●	●	●	●	●	●	●	///		
P1D-S040MS-XXXX	40	●	●	●	●	●	●	●	●	●	●	●	●	●	●	●	///		
P1D-S050MS-XXXX	50	●	●	●	●	●	●	●	●	●	●	●	●	●	●	●	///		
P1D-S063MS-XXXX	63	●	●	●	●	●	●	●	●	●	●	●	●	●	●	●	///		
P1D-S080MS-XXXX	80	●	●	●	●	●	●	●	●	●	●	●	●	●	●	●	///		
P1D-S100MS-XXXX	100	●	●	●	●	●	●	●	●	●	●	●	●	●	●	●	///		
P1D-S125MS-XXXX	125	●	●	●	●	●	●	●	●	●	●	●	●	●	●	●	///		

Operation data

Working pressure	Max 10 bar	
Working temperature	min	max
Standard	-20 °C	+80 °C
High temp version	-10 °C	+150 °C
Low temp version	-40 °C	+40 °C

Greased for life, does not normally need additional lubrication. If extra lubrication is given, this must always be continued.

Working medium, air quality

Working medium	Dry, filtered compressed air to ISO 8573-1 class 3.4.3.
----------------	---

Recommended air quality for cylinders

For best possible service life and trouble-free operation, ISO 8573-1 quality class 3.4.3 should be used. This means 5 µm filter (standard filter) dew point +3 °C for indoor operation (a lower dew point should be selected for outdoor operation) and oil concentration 1.0 mg oil/m³, which is what a standard compressor with a standard filter gives.

ISO 8573-1 quality classes

Quality class	Pollution		Water max. press. dew point (°C)	Oil max concentration (mg/m ³)
	particle size (µm)	max concentration (mg/m ³)		
1	0,1	0,1	-70	0,01
2	1	1	-40	0,1
3	5	5	-20	1,0
4	15	8	+3	5,0
5	40	10	+7	25
6	-	-	+10	-

Bores and strokes

P1D	32 - 125 mm
Standard strokes	25 - 500 mm according to ISO 4393, see page 17
Max stroke	2800 mm
Min stroke, P1D Clean	25 mm (0-2 sensors) 100 mm (3-4 sensors)

P1D Clean

Protection class	Hose-proof in accordance with IP65
Chemical resistance	Tested for normally used industrial detergents, both acid and alkaline

Material specification

Standard design

Body extrusion	Natural colour, anodised aluminium
End cover	Black anodised aluminium
End cover inserts	POM
End cover nuts/screws	Zinc plated steel 8.8
Piston rod nut	Zinc plated steel
Piston rod	Stainless steel, X 10 CrNiS 18 9
Scraper ring	PUR
Piston rod bearing	POM
Piston	POM
Piston bearing	POM
Magnetic ring	Plastic bound magnetic material
Piston bolt	Zinc plated steel
Piston seal	PUR
O-rings	Nitrile rubber, NBR
End-of-stroke washers	PUR
Cushioning seals	PUR
Cushioning screws	LCP

P1D Clean

Transparent moulding	Silicone
Transparent cover	ABS
Screws, sensor system	Stainless steel, A2
Upper seal and lower seal, protective cover	Santopren
Sealing plugs	PA
Piston rod nut	Stainless steel, A2

P1D Flexible Porting

Connection hardware Ø32-63	POM
Elbow fittings Ø32-63	PA
Straight fittings on body extrusion Ø32-63	PA
Straight fittings in ports	Nickel plated brass
Seal, connection hardware	Nitrile rubber NBR

P1D Tie-Rod

Tie-rods	Stainless steel, X 10 CrNiS 18 9
----------	----------------------------------

Design variants

Low temperature design	
Seals/scraper ring	Polyurethane PUR
Piston	Anodised aluminium
Piston/piston rod bearing	UHMWPE plastic
High temperature design	
Seals/scraper ring	Fluorocarbon rubber, FPM
Piston	Anodised aluminium
Piston/piston rod bearing	Bronze filled PTFE

Low pressure hydraulics	
Seals/scraper ring	Nitrile rubber, NBR
Piston	Anodised aluminium
Piston/piston rod bearing	UHMWPE plastic

Cylinders for dry rod operation	
Seals/scraper ring	FPM/HDPE

Option	
Piston rod material	Hard-chromium plated steel, Fe 490-2 FN Acid-proof steel, X 5 CrNiMo 17 13 3 Hard-chromium plated stainless steel, X 10 CrNiS 18 9

Cushioning characteristics

The diagram below is used for dimensioning of cylinders related to the cushioning capacity. The maximum cushioning capacity shown in the diagram assumes the following:

- Low load, i.e. low pressure drop across the piston
- Equilibrium speed
- Correctly adjusted cushioning screw
- 6 bar at cylinder port

The load is the sum of internal and external friction, plus any gravitational forces. At high relative load (pressure drop exceeding 1 bar), we recommend that for any given speed, the mass should be reduced by a factor of 2.5, or for a given mass, the speed should be reduced by a factor of 1.5. This is in relation to the maximum performance given in the diagram

Speed [m/s]

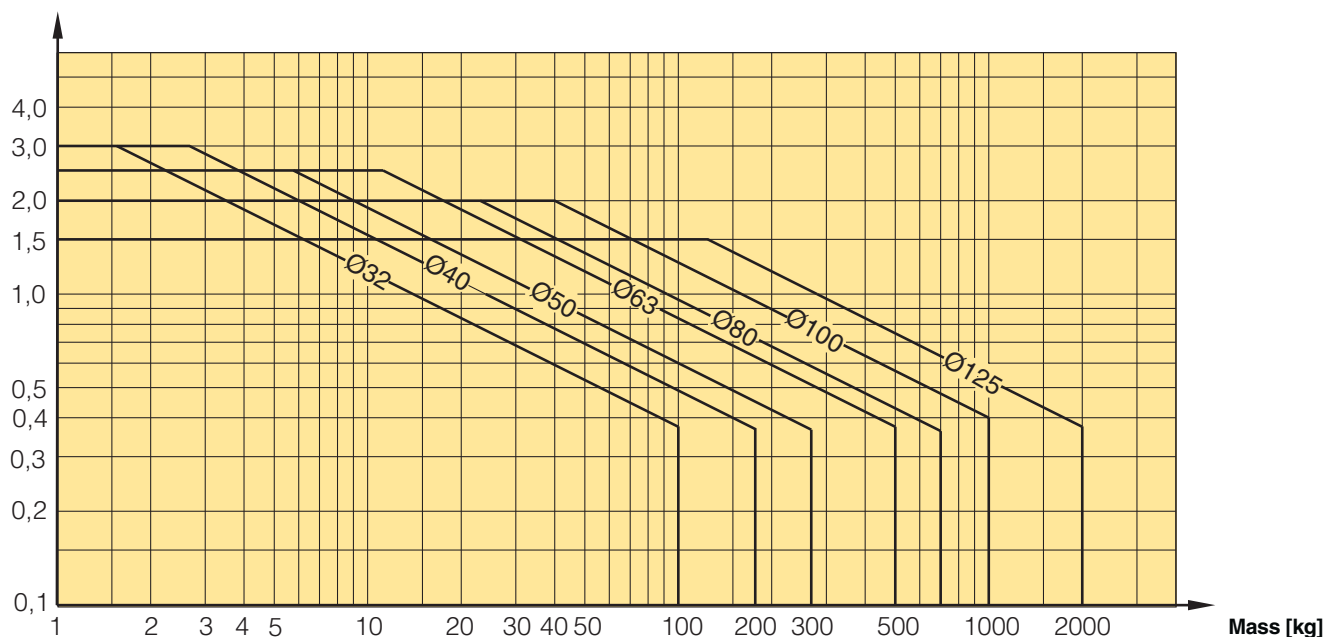

Guide for selecting suitable tubing

The selection of the correct size of tubing is often based on experience, with no great thought to optimizing energy efficiency and cylinder velocity. This is usually acceptable, but making a rough calculation can result in worthwhile economic gains.

The following is the basic principle:

1. The primary line to the working valve could be over sized (this does not cause any extra air consumption and consequently does not create any extra costs in operation).
2. The tubes between the valve and the cylinder should, however, be optimized according to the principle that an insufficient bore throttles the flow and thus limits the cylinder speed, while an oversized pipe creates a dead volume which increases the air consumption and filling time.

The chart below is intended to help when selecting the correct size of tube to use between the valve and the cylinder.

The following prerequisites apply:

The *cylinder load should be about 50% of the theoretical force (= normal load)*. A lower load gives a higher velocity and vice versa. The tube size is selected as a function of the *cylinder bore*, the desired *cylinder velocity* and the *tube length* between the valve and the cylinder.

If you want to use the capacity of the valve to its maximum, and obtain maximum speed, the tubing should be chosen so that they at least correspond with the equivalent restriction diameter (see description below), so that the tubing does not restrict the total flow. This means that a short tubing must have at least the equivalent restriction diameter. If the tubing is longer, choose it from the table below. Straight fittings should be chosen for highest flow rates. (Elbow and banjo fittings cause restriction.)

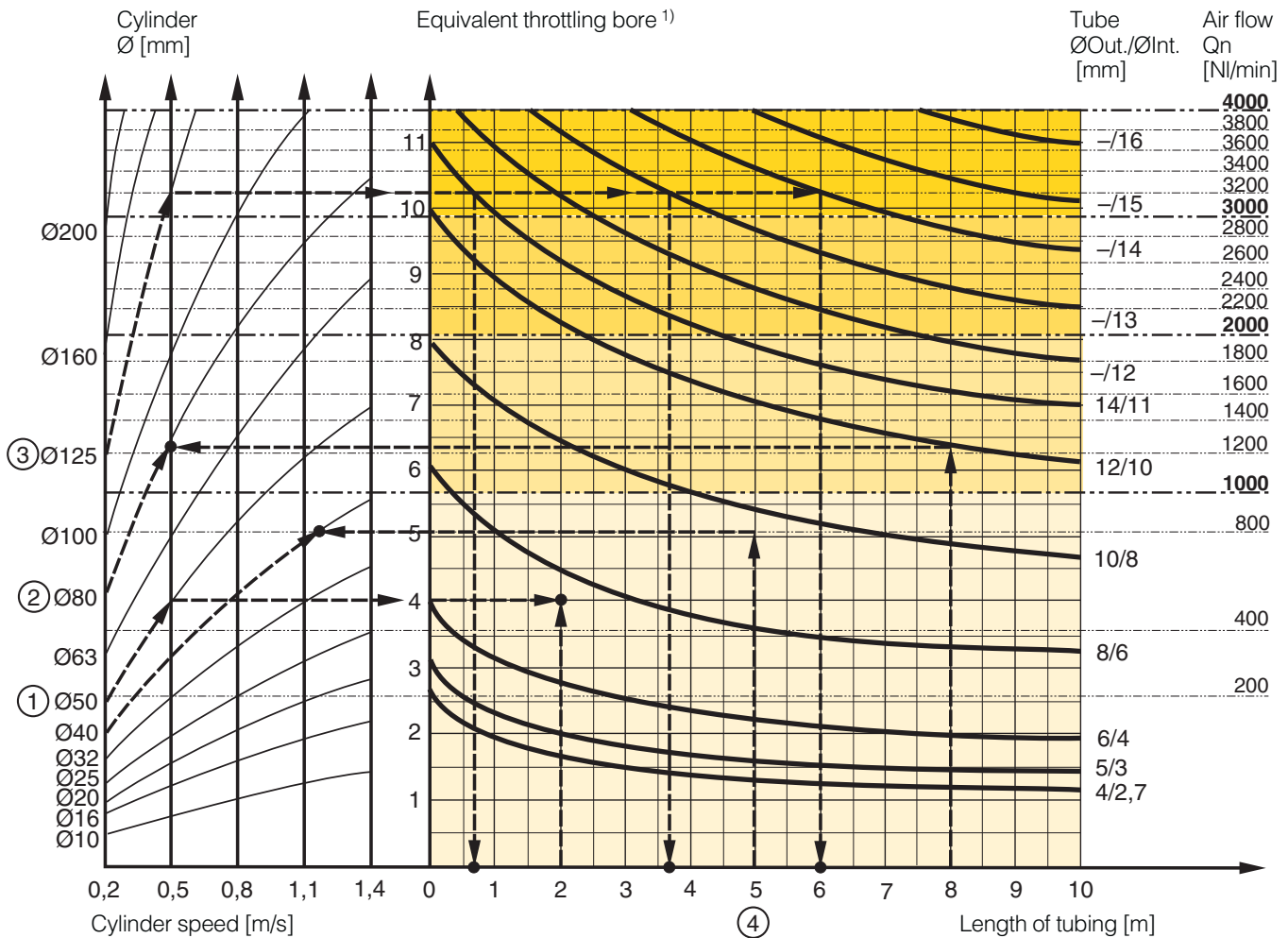

1) The "equivalent throttling bore" is a long throttle (for example a tube) or a series of throttles (for example, through a valve) converted to a short throttle which gives a corresponding flow rate. This should not be confused with the "orifice" which is sometimes specified for valves. The value for the orifice does not normally take account of the fact that the valve contains a number of throttles.

2) Qn is a measure of the valve flow capacity, with flow measured in litre per minute (l/min) at 6 bar(e) supply pressure and 1 bar pressure drop across the valve.

Example ①: Which tube diameter should be used?

A 50 mm bore cylinder is to be operated at 0.5 m/s. The tube length between the valve and cylinder is 2 m. In the diagram we follow the line from 50 mm bore to 0.5 m/s and get an “equivalent throttling bore” of approximately 4 mm. We continue out to the right in the chart and intersect the line for a 2 m tube between the curves for 4 mm (6/4 tube) and 6 mm (8/6 tube). This means that a 6/4 tube throttles the velocity somewhat, while an 8/6 tube is a little too large. We select the 8/6 tube to obtain full cylinder velocity.

Example ②: What cylinder velocity will be obtained?

A 80 mm bore cylinder will be used, connected by 8 m 12/10 tube to a P2L-B valve. What cylinder velocity will we get? We refer to the diagram and follow the line from 8 mm tube length up to the curve for 12/10 tube. From there, we go horizontally to the curve for the Ø80 cylinder. We find that the velocity will be about 0.5 m/s.

Example ③: What is the minimum inner diameter and maximum length of tube?

For an application a 125 mm bore cylinder will be used. Maximum velocity of piston rod is 0.5 m/s. The cylinder will be controlled by a P2L-D valve. What diameter of tube can be used and what is maximum length of tube.

We refer to the diagram. We start at the left side of the diagram cylinder Ø125. We follow the line until the intersection with the velocity line of 0.5 m/s. From here we draw a horizontal line in the diagram. This line shows us we need an equivalent throttling bore of approximately 10 mm. Following this line horizontally we crosses a few intersections. These intersections shows us the minimum inner diameter (rightside diagram) in combination with the maximum length of tube (bottomside diagram).

For example:

Intersection one: When a tube (14/11) will be used, the maximum length of tube is 0.7 meter.

Intersection two: When a tube (—/13) will be used, the maximum length of tube is 3.7 meter.

Intersection three: When a tube (—/14) will be used, the maximum length of tube is 6 meter.

Example ④: Determining tube size and cylinder velocity with a particular cylinder and valve?

For an application using a 40 mm bore cylinder with a valve with $Q_n=800$ NI/min. The distance between the cylinder and valve has been set to 5 m.

Tube dimension: What tube bore should be selected to obtain the maximum cylinder velocity? Start at pipe length 5 m, follow the line up to the intersection with 800 NI/min. Select the next largest tube diameter, in this case Ø10/8 mm.

Cylinder velocity: What maximum cylinder velocity will be obtained? Follow the line for 800 NI/min to the left until it intersects with the line for the Ø40 mm cylinder. In this example, the speed is just above 1.1 m/s.

Valve series with respective flows in NI/minute

Valve series	Qn in NI/Min
Valvetronic Solstar	33
Interface PS1	100
Valvetronic Interface 2000	100
B2 Series	168
Adex A05	173
Moduflex size 1, (2 x 3/2)	220
Valvetronic PVL-B 5/3 closed centre, 6 mm push in	290
Moduflex size 1, (4/2)	320
B43 Manual and mechanical	340
Valvetronic PVL-B 2 x 2/3, 6 mm push in	350
Valvetronic PVL-B 5/3 closed centre, G1/8	370
Valvetronic PVL-B 2 x 3/2 G1/8	440
Valvetronic PVL-B 5/2, 6 mm push in	450
Valvetronic PVL-B 5/3 vented centre, 6 mm push in	450
Moduflex size 2, (2 x 3/2)	450
Compact Isomax DX01	480
Flowstar P2V-A	520
Valvetronic PVL-B 5/3 vented centre, G1/8	540
Valvetronic PVL-B 5/2, G1/8	540
Valvetronic PVL-C 2 x 3/2, 8 mm push in	540
Adex A12	560
Valvetronic PVL-C 2 x 3/2 G1/8	570
Compact Isomax DX02	700
Valvetronic PVL-C 5/3 closed centre, 8 mm push in	700
Valvetronic PVL-C 5/3 vented centre, G1/4	700
VIKING P2L-A	760
B3 Series	780
Valvetronic PVL-C 5/3 closed centre, G1/4	780
Moduflex size 2, (4/2)	800
Valvetronic PVL-C 5/2, 8 mm push in	840
Valvetronic PVL-C 5/3 vented centre, 8 mm push in	840
Valvetronic PVL-C 5/2, G1/4	840
VIKING P2L-B	1020
Flowstar P2V-B	1090
ISOMAX DX1	1120
B53 Manual and mechanical	1160
B4 Series	1170
Airline Isolator Valve VE22/23	1470
ISOMAX DX2	2880
VIKING P2L-D	2880
ISOMAX DX3	4360
Airline Isolator Valve VE42/43	5520
Airline Isolator Valve VE82/83	13680

Introduction to the ATEX directive

Explosive atmospheres

Directive 94/9/EC defines an explosive atmosphere as a mixture of:

- a) **flammable substances** – gases, vapours, mists or dusts
 - b) with **air**
 - c) under specific **atmospheric conditions**
 - d) in which, after ignition has occurred, combustion spreads to the entire flammable mixture
- (NB: with regard to dust, it may be that not all dust is combusted after ignition has occurred)

An atmosphere with the potential to become an explosive atmosphere during operating conditions and/or under the influence of the surroundings is defined as a **potentially explosive atmosphere**. Products covered by directive 94/9/EC are defined as intended for use in potentially explosive atmospheres.

Harmonised European ATEX standard

The European Union has adopted two harmonised directives in the field of health and safety. The directives are known as ATEX 100a and ATEX 137.

Directive ATEX 100a (94/9/EC) lays down minimum safety requirements for products intended for use in potentially explosive atmospheres in European Union member states. Directive ATEX 137 (99/92/EC) defines minimum requirements for health and safety at the workplace, for working conditions and for the handling of products and materials in potentially explosive atmospheres. This directive also divides the workplace into **zones** and defines criteria by which products are **categorised** within these zones.

The table below describes the **zones** in an installation where there is a potential for explosive atmospheres. The **owner** of the installation must analyse and assess the area in which the explosive gas/dust mixture may occur, and if necessary must divide it into **zones**. This process of zoning then allows the correct plant and equipment to be selected for use in the area.

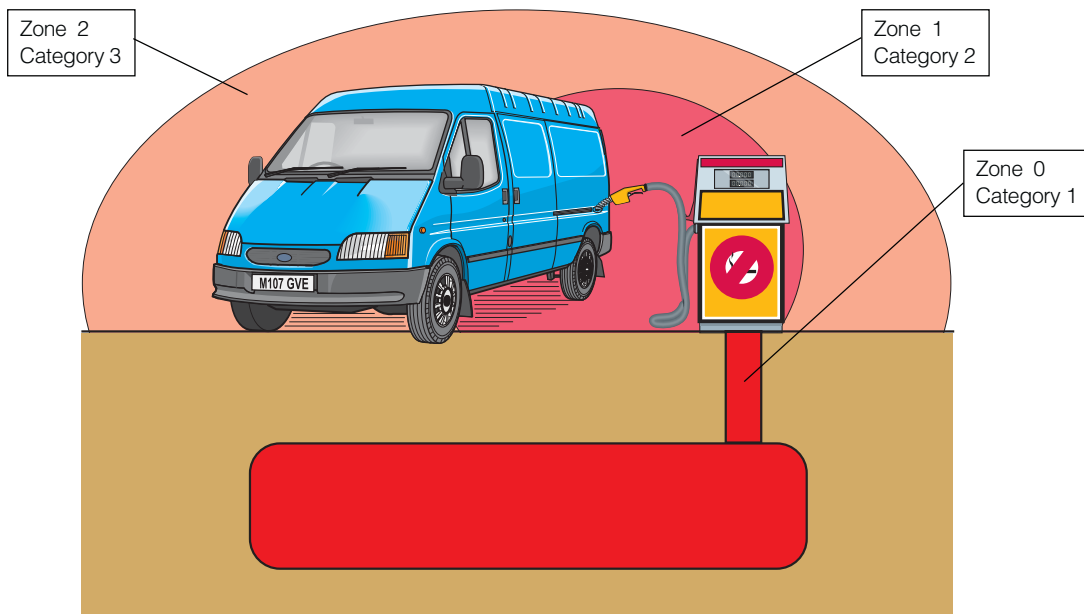

Zones		Presence of potentially explosive atmosphere	Type of risk
Gas G	Dust D		
0	20	Present continuously or for long periods	Permanent
1	21	Likely to occur in normal operation occasionally	Potential
2	22	Not likely to occur in normal operation but, if it does occur, will persist for a short period only	Minimal

The ATEX directive has been in force throughout the European Union since 1 July 2003, replacing the existing divergent national and European legislation relating to explosive atmospheres. Please note that for the first time, the directive covers mechanical, hydraulic and pneumatic equipment and not just electrical equipment as before.

With regard to the **Machinery directive 98/37/EC**, note that a number of external requirements in 94/9/EC refer to hazards arising from potentially explosive atmospheres, where the Machinery directive only contains general requirements relating to explosion safety (Annex I 1.5.7). As a result, directive 94/9/EC (ATEX 100a) takes precedence over the Machinery directive with regard to explosion protection in potentially explosive atmospheres. The requirements in the Machinery directive are applicable to all other risks relating to machinery.

Levels of protection for the various equipment categories

The various equipment categories must be capable of operating in accordance with the manufacturer's operating specifications at defined levels of protection.

Level of protection	Category		Type of protection	Operating specifications
	Group I	Group II		
Very high	M1		Two independent means of protection or safety, ensuring that the equipment remains functional even in the event of two faults occurring independently of each other	The equipment remains energised and functional even with an explosive atmosphere present
Very high		1	Two independent means of protection or safety, ensuring that the equipment remains functional even in the event of two faults occurring independently of each other	The equipment remains energised and functional in zones 0, 1, 2 (G) and/or zones 20, 21, 22 (D)
High	M2		Protection suitable for normal operation and severe operating conditions	The equipment is de-energised in the event of an explosive atmosphere
High		2	Protection suitable for normal operation and frequent faults, or equipment in which faults normally have to be taken into account	The equipment remains energised and functional in zones 1, 2 (G) and/or zones 21, 22 (D)
Normal		3	Protection suitable for normal operation	The equipment remains energised and functional in zones 2 (G) and/or zones 22 (D)

Definition of groups (EN 1127-1)

Group I Equipment intended for use in underground parts of mines as well as those parts of surface installations of such mines likely to be endangered by flammable vapours and/or flammable dusts.

Group II Equipment intended for use in other places exposed to explosive atmospheres.

Group	I mines, combustible vapours		II other potentially explosive atmospheres (gases, dust)					
	M1	M2	1		2		3	
Category								
Atmosphere*			G	D	G	D	G	D
Zone			0	20	1	21	2	22

G = gas and D = dust

Temperature classes

Classification of flammable gases and vapours on the basis of ignition temperature

Temperature class	Ignition temperature °C
T1	Over 450
T2	(300) – 450
T3	(200) – 300
T4	(135) – 200
T5	(100) – 135
T6	(85) - 100

Declaration of conformity

The product catalogues contain copies of the declaration of conformity demonstrating that the product meets the requirements of directive 94/9/EC.

The declaration is only valid in conjunction with the instructions contained in the installation manual relating to the safe use of the product throughout its service life.

The instructions relating to the conditions in the surrounding area are particularly important, as the certificate is invalidated if the instructions are found not to have been adhered to during operation of the product.

If there is any doubt as to the validity of the certificate of conformity, contact Parker Hannifin customer service.

Operation, installation and maintenance

The installation manual of the product contains instructions relating to the safe storage, handling, operation and servicing of the product.

The manual is available in different languages, and can be downloaded from www.parker.com/euro_pneumatic.

This document must be made accessible in a suitable place near where the product is installed. It is used as a reference for all personnel authorised to work with the product throughout its service life.

We, the manufacturer, reserve the right to modify, extend or improve the installation manual in the interests of the users.

For more information about ATEX see EUs homepage: <http://europa.eu.int/comm/enterprise/atex/>



Safety instructions for the P1D-S cylinder with accessories

Supplementary safety instructions for P1D-S cylinders installed in Ex-areas

Serious, even fatal, damage or injury may be caused by the hot moving parts of the P1D cylinders in the presence of explosive gas mixtures and concentrations of dust.

All installation, connection, commissioning, servicing and repair work on P1D cylinders must be carried out by qualified personnel taking account of the following

- These instructions
- Markings on the cylinder
- All other planning documents, commissioning instructions and connection diagrams associated with the application.
- Provisions and requirements specific to the application
- National/international regulations (explosion protection, safety and accident prevention)

Real life applications

P1D cylinders are designed to provide linear movement in industrial applications, and should only be used in accordance with the instructions in the technical specifications in the catalogue, and within the operating range indicated on the rating plate. The cylinders meet the applicable standards and requirements of directive 94/9/EC (ATEX)

The cylinders must not be used underground in mines susceptible to firedamp and/or flammable dusts. The cylinders are intended for use in areas in which explosive atmospheres caused by gases, vapours or mists of flammable liquids, or air/dust mixtures may be expected to occur during normal use (infrequently)

Checklist

Before using the cylinders in an Ex-area, you should check the following: Do the specifications of the P1D-S cylinder match the Ex-classification of the area of use in accordance with directive 94/9/EC (previously ATEX 100a)

- Equipment group
 - Ex-equipment category
 - Ex-zone
 - Temperature class
 - Max. surface temperature
1. When installing the P1D-S cylinder, is it certain that there is no potentially explosive atmosphere, oil, acids, gases, vapours or radiation?
 2. Is the ambient temperature as specified in the technical data in the catalogue at all times?
 3. Is it certain that the P1D-S cylinder is adequately ventilated and that no forbidden additional heat is added?
 4. Are all the driven mechanical components ATEX certified?
 5. Check that the P1D-S cylinder is safely earthed.
 6. Check that the P1D-S cylinder is supplied with compressed air. Explosive gas mixtures must not be used for driving the cylinder.
 7. Check that the P1D-S cylinder is not equipped with a metal scraper ring (special version).

Installation requirements in Ex-areas

- The temperature of the supply air must not exceed the ambient temperature.
- The P1D-S cylinder may be installed in any position.
- An air treatment unit must be attached to the inlet of the P1D-S cylinder.
- The P1D-S cylinder must be connected to earth at all times, through its support, a metallic tube or separate conductor.
- The outlet of the P1D-S cylinder must not open within an Ex-area, but must be passed to the silencer or, preferably, removed and released outside the Ex-area.
- The P1D-S cylinder may only drive units that are ATEX certified.
- Ensure that the P1D-S cylinder is not exposed to forces greater than those permitted in accordance with the catalogue
- The P1D-S cylinder must be supplied with compressed air. Explosive gas mixtures must not be used
- P1D-S cylinders with metal scraper rings must not be used in Ex-areas

Inspecting cylinders during operation

The P1D cylinder must be kept clean on the outside, and a layer of dust/dirt thicker than 1 mm must never be allowed to form.

Strong solvents should not be used for cleaning, because they can cause the seal (material PUR) around the piston rod to swell, potentially increasing the temperature. Inspect and verify that the cylinder, with attachments, compressed air fittings, hoses, tubes, etc. meet the standards of "safe" installation.

Marking of cylinder P1D-S Standard (P1D-S***MS-****)



Communauté Européenne = EU
CE on the product shows that Parker Hannifin products meet one or more EU directives



Ex means that this product is intended for use in potentially explosive atmospheres

II

Stands for the equipment group (I = mines and II = other hazardous areas)

2GD

Stands for equipment category 2G means the equipment can be used in zones 1 and 2 where there is a risk involving gases, vapours or mists of combustible liquids and 2D in zones 21 and 22 where there is a risk involving dusts. 2GD Means the equipment can be used in zones 1, 2, 21 and 22.

c

Safe design (prEN 13463-5)

T4

If equipment is in temperature class T4, the maximum surface temperature must not exceed 135 °C. (To guarantee this, the product has been tested to ensure that the maximum is 130 °C. This provides a safety margin of 5 °K.)

120 °C

Maximum permitted surface temperature on P1D-S cylinder in atmospheres containing potentially explosive dusts.

Supplementary safety instructions for P8S- GPFLX/EX sensors installed in Ex-areas

Serious, even fatal, damage or injury may be caused by the hot moving parts of the P1D cylinders in the presence of explosive gas mixtures and concentrations of dust.

Instructions for use

Safety instructions

- Cylinder sensor ATEX classed for category II3G and II3D
- Ambient temperature $T_a = -20\text{ °C}$ to $+45\text{ °C}$
- Temperature class T4, or max. surface temperature of $T = 135\text{ °C}$
- Protection class IP67
- Read installation instructions before startup
- Installation, connection and commissioning must be carried out by trained personnel

Applications

- This sensor is designed for use in the T-groove of cylinders, and detects the magnetic field in potentially explosive areas. The sensor can only be installed in the T-groove of these cylinders.
- The sensor may also be installed on round cylinders by means of the following attachments:

P8S-TMC01 Suitable for P1S and P1A diameter 10 - 25 mm

P8S-TMC02 Suitable for P1S diameter 32 - 63 mm

P8S-TMC03 Suitable for P1S diameter 80 - 125 mm

The following data applies to these attachments:

- Ambient temperature $T_a = 0\text{ °C}$ to 45 °C
- Low energy absorption to EN 50 021
- The sensor may also be installed on tie-rod cylinders or profile cylinders by means of this attachment:

P8S-TMA0X Suitable for P1D-T diameter 32 - 125 mm, P1E-T diameter 160 – 200 mm and C41 diameter 160 – 200 mm

Installation

General: The sensor must be protected from UV radiation. The cable must be installed such that it is protected from external influences, for example it may be necessary to attach an external strain relief to the cable.

Technical data for sensor

Operating voltage $U_b = 18$ to 30 V DC
 Max. load current I_a \dot{U} 70 mA
 Ambient temperature: -20 °C to 45 °C

Commissioning

When connecting the sensor to a power source, please pay attention to the following

- a) the load data (operating voltage, continuous load current)
- b) the wiring diagram for the sensor

Maintenance

Our P8S-GPFLX/EX cylinder sensor is maintenance free, but the cable connections should be checked at regular intervals. The sensor must be protected from UV radiation. The sensor must be kept clean on the outside, and a layer of dirt thicker than 1 mm must never be allowed to form. Strong solvents should not be used for cleaning as they may damage the sensor.

P8S-GPFLX/EX cylinder sensor

CE  II3G EEx nA II T4X
 II3D 135 °C IP67



Communauté Européenne = EU



CE on the product shows that Parker Hannifin products meet one or more EU directives

Ex means that this product is intended for use in potentially explosive atmospheres

II

Stands for the equipment group (I = mines and II = other hazardous areas)

3G

Stands for the equipment category 3G means the equipment can be used in zone 2 where there is a risk involving gases, vapours or mists of combustible liquids

EEx

EEx means that this is an electrical product intended for use in Ex-areas

nA II

n Not ignitable to EN50021, A Explosion group tested with acetone, ethanol, toluene and xylene; II Not for use in the mining industry

T4 X

If equipment is in temperature class T4, the maximum surface temperature must not exceed 135 °C . (To guarantee this, the product has been tested to ensure that the maximum is 130 °C . This provides a safety margin of 5 °K .) X Must be installed in accordance with the installation manual

3D

Stands for equipment category 3D in zone 22 where there is a risk involving dusts.

135 °C

Maximum permitted surface temperature on the sensor in atmospheres containing potentially explosive dusts.

IP67

Satisfies protection class IP67

Components such as cylinder attachments, tube fittings, tubes, etc.

Components

Parker Hannifin guarantees that our cylinder attachments, tube fittings, tubes, etc. are not subject to the provisions of the ATEX directive.

A component means any item essential to the safe functioning of equipment and protective systems but with no autonomous function.

Components intended for incorporation into equipment or protective systems which are accompanied by an attestation of conformity with the ATEX directive, including a statement of their characteristics and how they must be incorporated into products, are considered to conform to the applicable provisions of directive 94/9/EC. Ex-components as defined in the European standard EN 50014 are components in the sense of the ATEX directive 94/9/EC as well. Components must not have the CE marking affixed unless otherwise required by other directives.

Examples of components:

- terminals
- push buttons assemblies
- relays
- empty flameproof enclosures
- ballasts for fluorescent lamps
- meters (e.g. moving coil)
- encapsulated relays and contactors, with terminals and/or flying leads

P1D Standard

CAD drawings on the Internet

Our home page www.parker.com/euro_pneumatic includes the AirCad Drawing Library with 2D and 3D drawings for the main versions.

AirCad™
Drawing Library

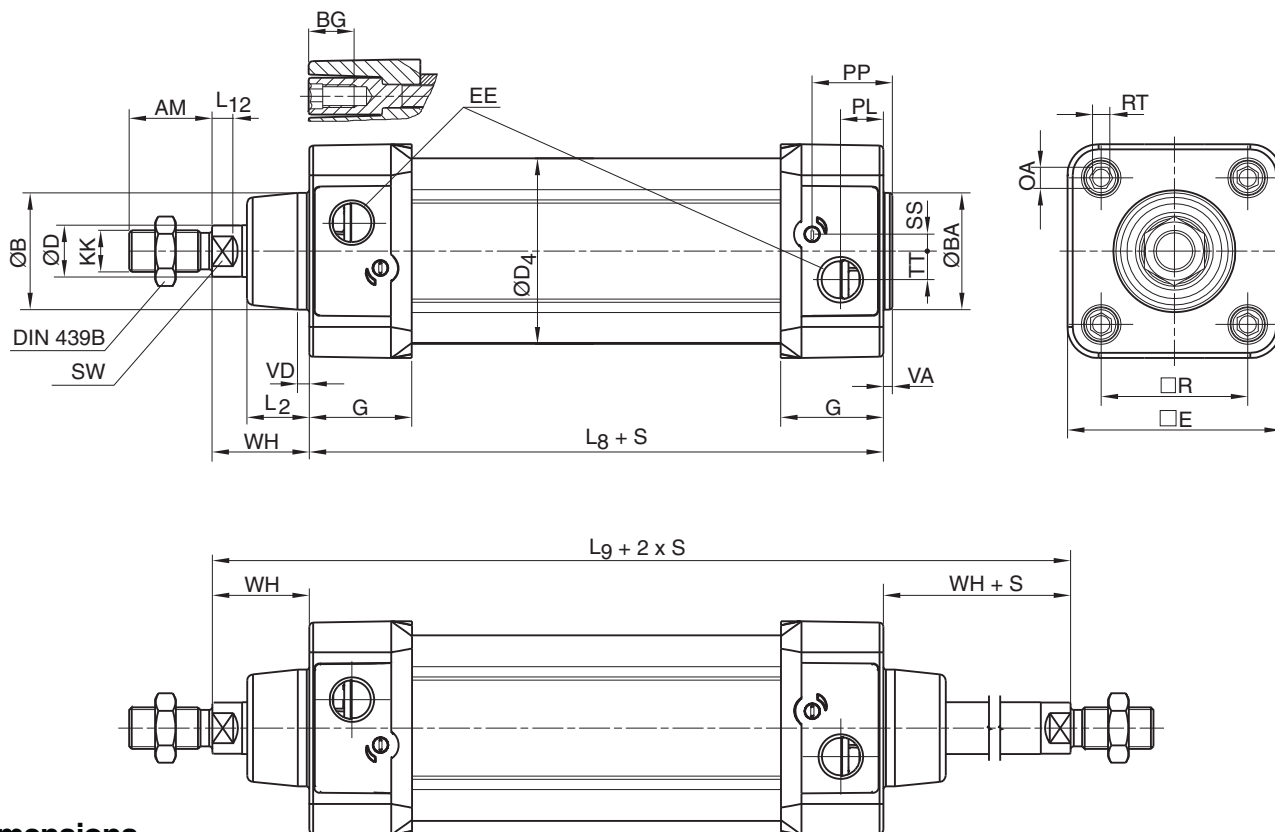

Dimensions

Cylinder bore mm	AM mm	B mm	BA mm	BG mm	D mm	D4 mm	E mm	EE mm	G mm	KK mm	L2 mm	L8 mm	L9 mm	L12 mm
32	22	30	30	16	12	45,0	50,0	G1/8	28,5	M10x1,25	16,0	94	146	6,0
40	24	35	35	16	16	52,0	57,4	G1/4	33,0	M12x1,25	19,0	105	165	6,5
50	32	40	40	16	20	60,7	69,4	G1/4	33,5	M16x1,5	24,0	106	180	8,0
63	32	45	45	16	20	71,5	82,4	G3/8	39,5	M16x1,5	24,0	121	195	8,0
80	40	45	45	17	25	86,7	99,4	G3/8	39,5	M20x1,5	30,0	128	220	10,0
100	40	55	55	17	25	106,7	116,0	G1/2	44,5	M20x1,5	32,4	138	240	14,0
125	54	60	60	20	32	134,0	139,0	G1/2	51,0	M27x2	45,0	160	290	18,0

Cylinder bore mm	OA mm	PL mm	PP mm	R mm	RT mm	SS mm	SW mm	TT mm	VA mm	VD mm	WH mm
32	6,0	13,0	21,8	32,5	M6	4,0	10	4,5	3,5	4,5	26
40	6,0	14,0	21,9	38,0	M6	8,0	13	5,5	3,5	4,5	30
50	8,0	14,0	23,0	46,5	M8	4,0	17	7,5	3,5	5,0	37
63	8,0	16,4	27,4	56,5	M8	6,5	17	11,0	3,5	5,0	37
80	6,0	16,0	30,5	72,0	M10	0	22	15,0	3,5	4,0	46
100	6,0	18,0	35,8	89,0	M10	0	22	20,0	3,5	4,0	51
125	8,0	28,0	40,5	110,0	M12	0	27	17,5	5,5	6,0	65

S=Stroke

Tolerances

Cylinder bore mm	B	BA	L ₈ mm	L ₉ mm	R mm	Stroke tolerance up to stroke 500 mm	Stroke tolerance for stroke over 500 mm
32	d11	d11	±0,4	±2	±0,5	+0,3/+2,0	+0,3/+3,0
40	d11	d11	±0,7	±2	±0,5	+0,3/+2,0	+0,3/+3,0
50	d11	d11	±0,7	±2	±0,6	+0,3/+2,0	+0,3/+3,0
63	d11	d11	±0,8	±2	±0,7	+0,3/+2,0	+0,3/+3,0
80	d11	d11	±0,8	±3	±0,7	+0,3/+2,0	+0,3/+3,0
100	d11	d11	±1,0	±3	±0,7	+0,3/+2,0	+0,3/+3,0
125	d11	d11	±1,0	±3	±1,1	+0,3/+2,0	+0,3/+3,0

P1D Clean

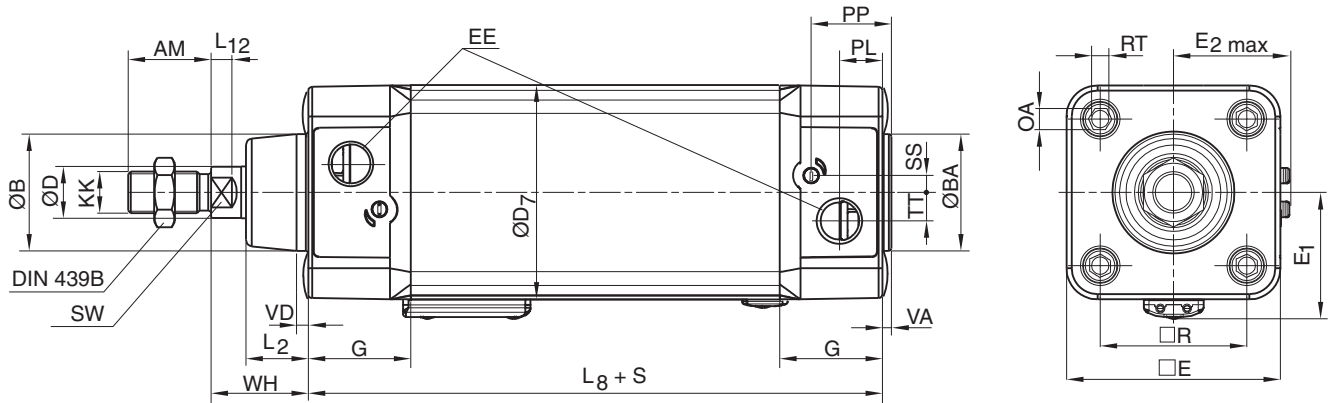

P1D Tie-Rod

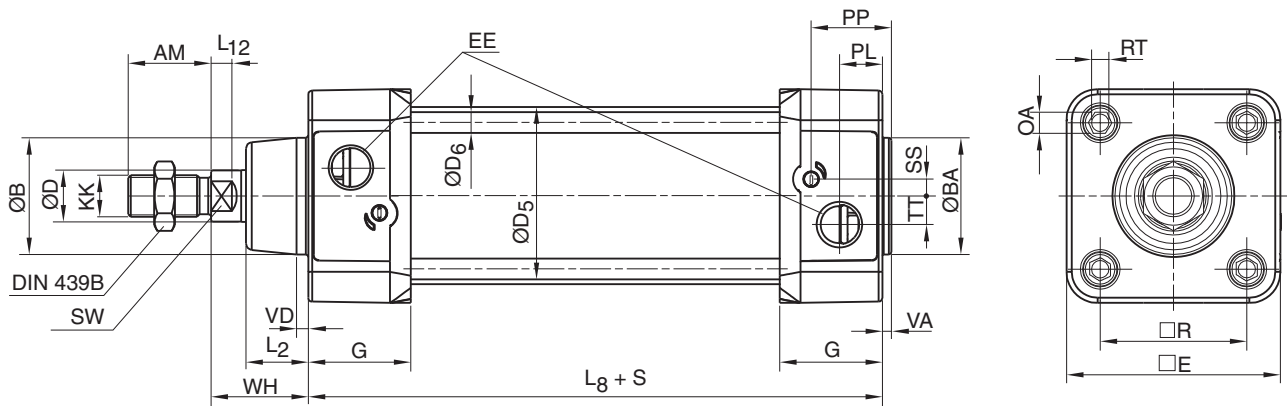

P1D Flexible Porting

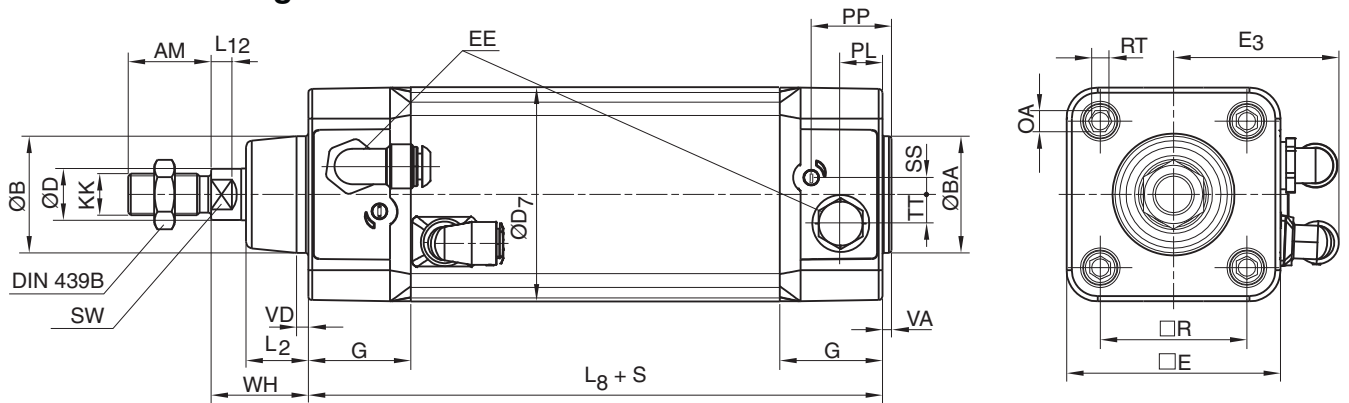

Dimensions

Cylinder bore	Elbow fittings, tubing Ømm					Straight fittings, tubing Ømm							
	D5	D6	D7	E1	E2max	4	6	8	10	4	6	8	10
mm	mm	mm	mm	mm	mm	E3	E3	E3	E3	E3	E3	E3	E3
32	36	5,3	49,6	32	30,0	42	44	-	-	38	40	-	-
40	44	5,3	57,3	36	34,7	46	48	-	-	42	44	-	-
50	55	7,1	69,3	42	40,7	-	-	56	76	-	-	48	50
63	68	7,1	82,3	49	46,2	-	-	64	83	-	-	55	75
80	86	8,9	99,3	57	54,7	-	-	-	-	-	-	-	-
100	106	8,9	117,6	68	64,0	-	-	-	-	-	-	-	-
125	132	10,8	142,8	81	75,5	-	-	-	-	-	-	-	-

Other dimensions, see opposite page

P1D Flexible Porting Ø80 - Ø125 can be ordered with threaded ports only or with factory-fitted elbow or straight push-in fittings (see position 20 in the order code key page 32)

The simple and complete order key

The P1D order key is based on the same principles as its predecessors, the P1C and P1E. This makes it easy to identify and order all common cylinder versions. The change-over from our previous cylinder ranges to the equivalent P1D cylinders is logical and simple. As far as possible, the same symbols as for P1C and P1E have been retained for the same functions. Most of the common cylinder types in the P1D-family have a 15-digit order number.

Many of our new cylinder versions, e.g. P1D Clean and P1D Flexible Porting, and complete working units (with factory-fitted cylinder mountings, sensors etc.) are defined by a 20-digit order number. There is only one single order key for P1D, which thus contains the 15-digit order numbers for the most common cylinder types and 20-digit order numbers for cylinders with more functions. Remember that there are always 15 or 20 positions in the order number – never any figure in between.

P1D Standard and P1D Tie rod

All common P1D cylinders have the same order number as their predecessors, P1C and P1E, but with the C or E replaced by D.



Valid for P1D-S***MS-****, see ATEX information pages 18 - 21.

1	2	3	4	5	6	7	8	9	10	11	12	13	14	15
P	1	D	-	S	0	3	2	M	S	-	0	1	0	0

Cylinder version	
S	Standard
C	Clean ²⁾
F	Flexible Porting
T	Tie-Rod

Stroke (mm)	
e.g. 0100	= 100 mm
Optional stroke lengths up to 2800 mm. Standard strokes see table page 14	

Cylinder bore mm
032
040
050
063
080
100
125

End cover screws						Function
Standard			Stainless steel ²²⁾			
Std scraper	HDPE scraper ²³⁾	FPM scraper	Std scraper	HDPE scraper ²³⁾	FPM scraper	
M	D	V	A	H	W	Double- acting
F	E	B	G	Y	Z	Double- acting through rod
2	6	8	-	-	-	Duplex back-to-back
C	-	-	-	-	-	Tandem

Piston rod material				Seals
Stainless steel	Chromium-plated steel	Acid-proof steel	Chrom.-pl. stainless steel	
S	C	M	R	Standard -20 °C to +80 °C.
F	G	N	D	High temperature version ⁶⁾ -10 °C to +150 °C. No magnetic function
L	K	P	E	Low temperature version ⁶⁾ -40 °C to +40 °C.
-	J	-	Z	Low pressure hydraulic ^{6) 24)}

2) P1D Clean without sensor function, see page 37.

6) For P1D-S and P1D-T.

22) If stainless steel end cover screws are selected, the piston rod nuts are also supplied in stainless steel.

23) For dry rod operation.

24) The seal system for low pressure hydraulics demands a hard chromed surface for proper function.

Example 1 Standard, double acting cylinder

Standard cylinder with standard scraper ring (PUR), standard piston rod material (stainless steel) and standard temperature range.

P1D	Compare P1C and P1E
P1D-S032MS-0160	P1C-S032MS-0160 P1E-S032MS-0160
P1D-S100MS-0400	P1C-S100MS-0400 P1E-S100MS-0400

Example 2 Tie-Rod design, double acting cylinder

Tie-rod cylinder with standard scraper ring (PUR), hard chromed steel piston rod and standard temperature range.

P1D	Compare P1E
P1D-T040MC-0125	P1E-T040MC-0125

P1D Standard

The order numbers on this page refer to P1D Standard without sensors. The cylinders can be ordered with sensors, fittings, piston rod and cylinder mountings, speed controls etc. for efficient logistics. Please refer to the order key to select cylinders with factory-fitted accessories.



CE **Ex** **II 2GD cT4 120 °C**

See ATEX information pages 18 - 21.

P1D Standard

Double-acting

Cyl. bore mm	Stroke mm	Order code
32	25	P1D-S032MS-0025
	40	P1D-S032MS-0040
	50	P1D-S032MS-0050
	80	P1D-S032MS-0080
	100	P1D-S032MS-0100
	125	P1D-S032MS-0125
	160	P1D-S032MS-0160
	200	P1D-S032MS-0200
	250	P1D-S032MS-0250
	320	P1D-S032MS-0320
	400	P1D-S032MS-0400
500	P1D-S032MS-0500	
Conn. G1/8		
40	25	P1D-S040MS-0025
	40	P1D-S040MS-0040
	50	P1D-S040MS-0050
	80	P1D-S040MS-0080
	100	P1D-S040MS-0100
	125	P1D-S040MS-0125
	160	P1D-S040MS-0160
	200	P1D-S040MS-0200
	250	P1D-S040MS-0250
	320	P1D-S040MS-0320
	400	P1D-S040MS-0400
500	P1D-S040MS-0500	
Conn. G1/4		
50	25	P1D-S050MS-0025
	40	P1D-S050MS-0040
	50	P1D-S050MS-0050
	80	P1D-S050MS-0080
	100	P1D-S050MS-0100
	125	P1D-S050MS-0125
	160	P1D-S050MS-0160
	200	P1D-S050MS-0200
	250	P1D-S050MS-0250
	320	P1D-S050MS-0320
	400	P1D-S050MS-0400
500	P1D-S050MS-0500	
Conn. G1/4		
63	25	P1D-S063MS-0025
	40	P1D-S063MS-0040
	50	P1D-S063MS-0050
	80	P1D-S063MS-0080
	100	P1D-S063MS-0100
	125	P1D-S063MS-0125
	160	P1D-S063MS-0160
	200	P1D-S063MS-0200
	250	P1D-S063MS-0250
	320	P1D-S063MS-0320
	400	P1D-S063MS-0400
500	P1D-S063MS-0500	
Conn. G3/8		

P1D Standard

Double-acting

Cyl. bore mm	Stroke mm	Order code
80	25	P1D-S080MS-0025
	40	P1D-S080MS-0040
	50	P1D-S080MS-0050
	80	P1D-S080MS-0080
	100	P1D-S080MS-0100
	125	P1D-S080MS-0125
	160	P1D-S080MS-0160
	200	P1D-S080MS-0200
	250	P1D-S080MS-0250
	320	P1D-S080MS-0320
	400	P1D-S080MS-0400
500	P1D-S080MS-0500	
Conn. G3/8		
100	25	P1D-S100MS-0025
	40	P1D-S100MS-0040
	50	P1D-S100MS-0050
	80	P1D-S100MS-0080
	100	P1D-S100MS-0100
	125	P1D-S100MS-0125
	160	P1D-S100MS-0160
	200	P1D-S100MS-0200
	250	P1D-S100MS-0250
	320	P1D-S100MS-0320
	400	P1D-S100MS-0400
500	P1D-S100MS-0500	
Conn. G1/2		
125	25	P1D-S125MS-0025
	40	P1D-S125MS-0040
	50	P1D-S125MS-0050
	80	P1D-S125MS-0080
	100	P1D-S125MS-0100
	125	P1D-S125MS-0125
	160	P1D-S125MS-0160
	200	P1D-S125MS-0200
	250	P1D-S125MS-0250
	320	P1D-S125MS-0320
	400	P1D-S125MS-0400
500	P1D-S125MS-0500	
Conn. G1/2		

The cylinders are supplied complete with one zinc plated steel piston rod nut.

P1D cylinders with piston rod mountings and end cover screw sealing plugs

Using the 20-digit order number, it is possible to order complete working units with factory installed piston rods and cylinder mountings, sensors etc.

Piston rod mountings and sealing plugs for the cylinder end cover screws are specified in position 16 in accordance with the order key below.

Please note that an order code with sealing plugs must be combined with selecting a cylinder mounting in position 17. The sealing plugs are installed in the end cover screws which are not used.

1	2	3	4	5	6	7	8	9	10	11	12	13	14	15	16	17	18	19	20
P	1	D	-	S	0	4	0	M	S	-	0	3	2	0	C	N	N	N	N

Factory-fitted piston rod mountings and sealing plugs			
	No plugs	With plugs ⁸⁾	
S	A		Swivel rod eye, zinc-plated steel
T	1		Swivel rod eye, stainless steel ¹⁰⁾
V	E		Swivel rod eye, zinc-plated steel and clevis bracket GA
W	2		Swivel rod eye, stainless steel and clevis bracket GA ¹⁰⁾
C	B		Clevis, zinc-plated steel
D	3		Clevis, stainless steel ¹⁰⁾
F	G		Flexo coupling, zinc-plated steel
X	P		One additional piston rod nut ⁹⁾
Y	4		Piston rod nut in stainless steel ¹⁰⁾
Z	5		Piston rod nut in acid-proof steel
6	7		Without piston rod nut
H	L		Rod guidance module, H style, ball bearings ¹⁸⁾
J	M		Rod guidance module, H style, plain bearings ¹⁸⁾
K	Q		Rod guidance module, U style, plain bearings ¹⁸⁾
N	R		None

- 8) Valid only for cylinders with factory-fitted cylinder mountings. P1D Clean cylinders are always delivered with 4 sealing plugs.
- 9) P1D cylinders are always delivered with one piston rod nut in zinc-plated steel, except P1D Clean which is delivered with the piston rod nut in stainless steel. Codes X and P mean that the cylinder is delivered with one additional nut of the same type.
- 10) The piston rod nut in zinc-plated steel is replaced by a nut in stainless steel (P1D Clean is always delivered with one piston rod nut in stainless steel).
- 18) Only for bore 32-100 mm

Example of piston rod fittings and end cover screw sealing plugs

P1D-S040MS-0320CNNNN P1D Standard with a zinc plated clevis on the piston rod and without sealing plugs in the end cover screws
 P1D-S080MS-0250ATNNN P1D Standard with swivel rod eye on the piston rod, clevis bracket MP2 installed on rear end cover and sealing plugs in the cylinder end cover screws in the front end.

P1D cylinders with central trunnion and cylinder mountings

There are three different types of central trunnion in the P1D family. A central trunnion for the P1D Standard and one for the P1D Tie-Rod placed in the centre or an optional location of the cylinder, or a flange mounted central trunnion on the front or rear end cover that fits all P1D cylinders.

For the P1D, the central trunnion is available among the cylinder mountings in position 17. If G or 7 appears in position 17, the position of the central trunnion should be specified as a three-digit measurement in positions 18-20. A measurement of 000 indicates a loose central trunnion. If D or 6 appears in

position 17, the central trunnion is always centred on the cylinder (no measurement specified in positions 18-20). For some of our previous cylinder series, the central trunnion is selected back in position 5, e.g. P1C-C. Remember that C in position 5 for P1D means the Clean cylinder version and nothing else!

It is possible to equip the cylinders with factory installed piston rod mountings, sensors, fittings etc. in the usual way. For the version with optional location of the central trunnion or loose central trunnion, no choices can be made for positions 18-20 since they are used for the XV dimension. (See page 56)

1	2	3	4	5	6	7	8	9	10	11	12	13	14	15	16	17	18	19	20
P	1	D	-	T	0	4	0	M	S	-	0	3	2	0	N	D	N	N	N

Cylinder version	
S	Standard
C	Clean ²⁾
F	Flexible Porting
T	Tie-Rod

Cylinder mountings		
90°	0°	90° = shaft square to, 0° = shaft in line with ports ⁵⁾
1	3	Flange MF1/MF2 in front end
B	4	Flange MF1/MF2 in rear end
2	K	Flange MF1/MF2 in both ends
F	-	Foot brackets MS1 (both ends)
C	U	Clevis bracket GA
E	V	Clevis bracket MP4
S	W	Swivel eye bracket
T	Y	Clevis bracket MP2
L	Z	Clevis bracket MP2+MP4
X	5	Clevis bracket MP2+pivot bracket with rigid bearing
Q	0	Clevis bracket GA + pivot bracket with swivel bearing
M	A	Clevis bracket GA +swivel eye bracket
D	6	Centre trunnion MT4, mid position ⁶⁾
G	7	Trunnion MT4, optional pos. (XV-meas. pos 18-20) ⁷⁾
H	P	Trunnion flange in front end
J	8	Trunnion flange in rear end
N		None

2) P1D Clean without sensor function, see page 37.

5) Shaft or pivots square to or in line with the cylinder ports.

6) For versions P1D-S and P1D-T

7) For P1D-S and P1D-T, XV-measure (from the piston rod thread according to ISO to the centre of the pivots) stated in mm in positions 18-20 (max 999, or 000 if loose central trunnion specified). For XV measures, see page 56.

Examples of central trunnion

P1D-S050MS-0250NDNNN

P1D Standard rod cylinder with central trunnion installed in centre of cylinder.

P1D-T050MS-0250NG205

P1D Tie rod cylinder with central trunnion installed on XV dimension specified in positions 18, 19 and 20.

P1D-S032MS-0160NHNNN

P1D Standard cylinder with trunnion flange mounted on front end cover.

P1D-S032MS-0160NJNNN

P1D Standard cylinder with trunnion flange mounted on rear end cover.

Examples of other combinations

P1D-C050MS-02501HQN6

P1D Clean cylinder with trunnion flange mounted on front end cover, two reed sensors, 8 mm connector (1 m cable), cable connection on rear end cover, factory installed stainless steel swivel rod eye, push-in fittings (Prestolok, nickel plated brass) low elbow type for 6 mm tube, sealing plugs installed in unused end cover screws (code 1 for stainless swivel rod eye).

P1D-F080MSJ0400XJFN0

P1D Flexible Porting cylinder with trunnion flange mounted on rear end cover, two threaded connections in rear end cover, extra zinc plated steel piston rod nut (i.e. a total of two zinc plated steel nuts), two factory installed electronic sensors, 24 VDC, PNP type, 3 m cable, factory installed push-in fittings (Prestolok, nickel plated brass) low elbow type for 10 mm tube.

Factory-fitted sensors

All P1D cylinders can be supplied with up to four factory installed sensors (standard reed or electronic sensors) in specially designed grooves. Both cable and sensor are protected in the groove. Choose a sensor with 3 or 10 m cable or with 8 mm connector.

P1D Clean has a system of sensors fully integrated in the body extrusion, in specially designed grooves underneath a transparent, sealed moulding. The factory installed sensors are

installed at the end positions and can then easily be moved anywhere along the entire stroke during commissioning. The sensors can be ordered with cable exit in the front end cover, rear end cover or at both end covers.

For cylinders with 3 sensors, 2 sensors are installed in the rear end position and one sensor in the front end position. Cylinders with 4 sensors are supplied with 2 sensors in each end position.

1	2	3	4	5	6	7	8	9	10	11	12	13	14	15	16	17	18	19	20
P	1	D	-	S	0	5	0	M	S	-	0	3	2	0	N	N	C	N	N

Factory-fitted sensors			
Front end or left ¹¹⁾	Rear end or right ¹¹⁾	Front and rear end	Cable exit
F	R	-	2 sensors 24 VDC pnp, 3 m cable
G	H	-	2 sensors 24 VDC pnp, 10 m cable
C	S	-	2 sensors 24 VDC pnp, 8 mm connector
K	L	-	2 sensors Reed type, 3 m cable
T	V	-	2 sensors Reed type, 10 m cable
M	Q	-	2 sensors Reed type, 8 mm connector
-	-	3	3 sensors 24 VDC pnp, 8 mm connector
-	-	Z	3 sensors Reed type, 8 mm connector
-	-	4	4 sensors 24 VDC pnp, 8 mm connector
-	-	W	4 sensors Reed type, 8 mm connector
6 ¹²⁾	7 ¹³⁾	8 ¹⁴⁾	No factory-fitted sensors P1D Clean
N			No sensors P1D (excl. P1D Clean)

11) Left and right valid for P1D Standard and P1D Tie-Rod seen from behind with the ports on top. The sensors can only be mounted on the left for P1D Flexible Porting.

12) No factory-fitted sensors, but prepared for cable exit in the front end (max. 2 sensors).

13) No factory-fitted sensors, but prepared for cable exit in the rear end (max. 2 sensors).

14) No factory-fitted sensors, but prepared for cable exit in both ends (max. 4 sensors).

Example of sensors

P1D-S050MS-0320NNC NN P1D Standard with two factory installed sensors 24 VDC PNP, 8 mm connector

P1D-C063MS-0250NNL NN P1D Clean with two factory installed Reed sensors, 3 m cable and cable connection at rear end cover on left side

P1D-F080MS-0400NNM NN P1D Flexible Porting with two factory installed Reed sensors, 8 mm connector

Pre-assembled fittings or speed controls

All P1D cylinders can be delivered with elbow or straight push-in fittings in nickel-plated brass (Prestolok) or speed controls in brass (series PTF). P1D Clean cylinders are factory-fitted nickel-plated versions of the PTF speed controls. Please see page 38 for the order code key for P1D Flexible Porting with pre-assembled fittings.

1	2	3	4	5	6	7	8	9	10	11	12	13	14	15	16	17	18	19	20	
P	1	D	-	S	0	5	0	M	S	-	0	3	2	0	N	N	N	N	N	8

Speed controls or fittings for tube dimension	
Speed controls ¹⁷⁾ Series PTF 4PB ¹⁶⁾	
X	in both ends for tube 4 mm
Y	in both ends for tube 6 mm
Z	in both ends for tube 8 mm
P	in both ends for tube 10 mm
R	in both ends for tube 12 mm
Push-in fitting, elbow type for:	
4	Tube dimension 4 mm
6	Tube dimension 6 mm
8	Tube dimension 8 mm
0	Tube dimension 10 mm
2	Tube dimension 12 mm
Push-in fitting, straight type for:	
1	Tube dimension 4 mm
3	Tube dimension 6 mm
5	Tube dimension 8 mm
7	Tube dimension 10 mm
9	Tube dimension 12 mm
N	None

Available fittings and speed controls for P1D Standard			
Cyl. bore	Speed controls for tube	Elbow fitting for tube	Straight fitting for tube
32	4, 6, 8	4, 6, 8	4, 6, 8
40, 50	6, 8	4, 6, 8, 10, 12	4, 6, 8, 10, 12
63, 80	8, 10, 12	8, 10, 12	8, 10, 12
100, 125	12	12	10, 12

16) P1D Clean cylinders have factory fitted nickel plated versions of the PTF series.

17) Not available for P1D Flexible Porting bore 32-63 mm.

Example P1D Standard with factory-fitted fittings or speed controls

P1D-S050MS-0320NNNN8 P1D Standard cylinder with two push-in fittings, elbow type for 8 mm tube.
 P1D-S125MS-0400NNNNR P1D Standard cylinder with two speed controls for 12 mm tube.

Extended piston rod

All cylinders in the P1D family can be ordered with extended piston rod, for all piston rod materials. To make it possible to combine piston rod extension with all the functions and properties in the P1D system, the three positions which normally

specify cylinder bore are used to specify both bore and extension. When ordering a P1D cylinder with extended piston rod, specify this as below.

1	2	3	4	5	6	7	8	9	10	11	12	13	14	15
P	1	D	-	S	K	R	5	M	S	-	0	3	2	0

Cylinder bore mm	
K	32
L	40
M	50
N	63
P	80
Q	100
R	125

Piston rod extension			
E.g. KR5 = Cylinder bore 32 mm with piston rod extension = 255 mm			
01-99	1-99	N0-N9	220-229
A0-A9	100-109	P0-P9	230-239
B0-B9	110-119	Q0-Q9	240-249
C0-C9	120-129	R0-R9	250-259
D0-D9	130-139	S0-S9	260-269
E0-E9	140-149	T0-T9	270-279
F0-F9	150-159	U0-U9	280-289
G0-G9	160-169	V0-V9	290-299
H0-H9	170-179	W0-W9	300-309
J0-J9	180-189	X0-X9	310-319
K0-K9	190-199	Y0-Y9	320-329
L0-L9	200-209	Z0-Z9	330-339
M0-M9	210-219		

The maximum extended piston rod length that can be specified by the order key is 339 mm. If a longer extended piston rod is needed please contact us and we will organise a special part number.

By changing from 032 to KR5, the cylinder has been given a 255 mm extended piston rod. At the same time, the cylinder can be specified with all functions and properties in the other positions.

Example of an extended piston rod

P1D-SK45MS-0200 P1D Standard cylinder, bore 32 mm, with a 45 mm extended piston rod.
 P1D-TPD2MS-0500 P1D Tie-Rod cylinder, bore 80 mm, with 132 mm extended piston rod.

Piston rod in alternative materials

P1D has a polished stainless steel piston rod as standard. If you want a different material and/or surface treatment, please order this in combination with seal material in position 10.

Piston rod nuts are supplied in zinc plated steel as standard, but stainless steel piston rod nuts are always supplied for P1D Clean. If an alternative material is used, the piston rod nut is always supplied in the same material.

1	2	3	4	5	6	7	8	9	10	11	12	13	14	15
P	1	D	-	S	0	3	2	M	S	-	0	1	0	0

Piston rod material				Seals
Stainless steel	Chromium-plated steel	Acid-proof steel	Chrom.-pl. stainless steel	
S	C	M	R	Standard -20 °C to +80 °C.
F	G	N	D	High temperature version ⁶⁾ -10 °C to +150 °C. No magnetic function
L	K	P	E	Low temperature version -40 °C to +40 °C. ⁶⁾
-	J	-	Z	Low pressure hydraulic ⁶⁾ ²⁴⁾

6) For P1D-S and P1D-T.
 24) The seal system for low pressure hydraulics demands a hard chromed surface for proper function.

Example of piston rod material

P1D-S032MS-0100 P1D Standard cylinder, bore 32 mm, with stainless steel piston rod (standard)
 P1D-T040MC-0160 P1D Tie-Rod cylinder, bore 40 mm, with hard chromed steel piston rod

High and low temperature and low pressure hydraulics

The new P1D system contains cylinder versions for high and low temperature High and low temperature, and low pressure hydraulics. These versions have material and sealing systems specially designed for their particular temperature ranges. End covers and pistons are made entirely from metal, to give optimum function at high or low temperature in combination with seals made from specially tested materials and special grease. These variants are available with the P1D-S and P1D-T models. The low temperature version has a magnetic ring in the piston for proximity sensing (but please note that the sensors are normally specified for full performance down to -25 °C only), whereas the high temperature version does not have a magnetic ring in the piston.

The high temperature version is chosen by the letter F in position 10 (or G, D, N for other piston rod materials, see the table). The low temperature version is chosen by the letter L in position 10 (or K, E, P for other piston rod materials, see the table). Order cylinders for low pressure hydraulics by specifying the letter J (hard chromed steel piston rod) or Z (hard chromed stainless steel piston rod) in position 10 in the table below. Please note that this version requires a piston rod with hard chromed surface.

Certain restrictions apply to choosing sensors, piston rod mountings, cylinder mountings and fittings due to the temperature range. However, the high temperature cylinders can not be supplied with sensors, i.e. always code N in position 18.

1	2	3	4	5	6	7	8	9	10	11	12	13	14	15
P	1	D	-	S	0	6	3	M	F	-	0	3	2	0

Cylinder version		Piston rod material				Seals
S	Standard	Stainless steel	Chromium-plated steel	Acid-proof steel	Chrom.-pl. stainless steel	
C	Clean					
F	Flexible Porting					
T	Tie-Rod					
S		C	M	R		Standard -20 °C to +80 °C.
F		G	N	D		High temperature version ⁶⁾ -10 °C to +150 °C. No magnetic function.
L		K	P	E		Low temperature version ⁶⁾ -40 °C to +40 °C.
-		J	-	Z		Low pressure hydraulic ²⁴⁾ 24)

6) For P1D-S and P1D-T.

24)The seal system for low pressure hydraulics demands a hard chromed surface for proper function.

Examples of high and low temperature, and low pressure hydraulics

- | | |
|----------------------|---|
| P1D-S032MF-0125 | P1D cylinder, version S, high temperature design, no magnetic function. |
| P1D-S050ML-0250 | P1D cylinder, version S, low temperature design, built-in magnetic ring (but the sensors have normally acceptable function to -25 °C only). |
| P1D-S063MF-0320S1NNN | P1D cylinder, version S, high temperature design, no magnetic function, zinc plated steel swivel rod eye, flange on front end cover. |
| P1D-S050MJ-0200 | P1D cylinder, version S, low pressure hydraulic version, hard chromed piston rod, magnetic ring built in. |

Through piston rod

All P1D cylinders can be ordered with a through piston rod. Order this design in position 9 in combination with the scraper ring system as below.

1	2	3	4	5	6	7	8	9	10	11	12	13	14	15
P	1	D	-	S	0	3	2	F	S	-	0	1	0	0

End cover screws						Function
Standard			Stainless steel ²²⁾			
Std scraper	HDPE scraper ²³⁾	FPM scraper	Std scraper	HDPE scraper ²³⁾	FPM scraper	
M	D	V	A	H	W	Double- acting
F	E	B	G	Y	Z	Double- acting through rod

22) If stainless steel end cover screws are selected, the piston rod nuts are also supplied in stainless steel.

23) For dry rod operation.

Example of through piston rod

P1D-S032FS-0100 P1D Standard cylinder, bore 32 mm, with through piston rod
 P1D-T050FS-0125 P1D Tie-Rod cylinder, bore 50 mm, with through piston rod

3 and 4 position cylinders

Factory-fitted 3 and 4 position cylinders can be ordered in tie-rod design P1D-T. Through going tie-rods fix the two cylinders into a compact unit.

1	2	3	4	5	6	7	8	9	10	11	12	13	14	15	16	17	18	19	20
P	1	D	-	T	0	8	0	2	S	-	0	2	0	0	N	0	2	5	0

Cylinder version		End cover screws						Function
		Standard			Stainless steel ²²⁾			
		Std scraper	HDPE scraper ²³⁾	FPM scraper	Std scraper	HDPE scraper ²³⁾	FPM scraper	
S	Standard							
C	Clean							
F	Flexible Porting							
T	Tie-Rod							
		M	D	V	A	H	W	Double- acting
		F	E	B	G	Y	Z	Double- acting through rod
		2	6	8	-	-	-	3 and 4 position cylinders
		C	-	-	-	-	-	Tandem

22) If stainless steel end cover screws are selected, the piston rod nuts are also supplied in stainless steel.

23) For dry rod operation.

Equal stroke – 3 position cylinder

Specify letter T in position 5 (P1D-T) and figure 2 in position 9 (standard scraper ring)

Unequal stroke – 4 position cylinder

Specify letter T in position 5 (P1D-T) and figure 2 in position 9 (standard scraper ring)
 Specify the shortest stroke in the ordinary positions 12, 13, 14, 15 and the longest stroke in positions 17, 18, 19, 20.

Example of 3 and 4 position cylinders

P1D-T0322S-0200SNNN4 P1D Tie-Rod cylinder with 3 position design, swivel rod eye in zinc plated steel, factory installed plug-in fittings (Prestolok, nickel plated brass) for 4 mm tube.
 P1D-T0632S-0160 P1D Tie-Rod cylinder with 3 position design
 P1D-T0802S-0200N0250 P1D Tie-Rod cylinder with 4 position design with stroke 200 mm and 250 mm.

Tandem cylinders

The P1D-T is available in tandem design i.e. two cylinders in series, for almost double force. Order with the letter C in position 9.

1	2	3	4	5	6	7	8	9	10	11	12	13	14	15
P	1	D	-	T	0	4	0	C	S	-	0	3	2	0

End cover screws						Function
Standard			Stainless steel ²²⁾			
Std scraper	HDPE scraper ²³⁾	FPM scraper	Std scraper	HDPE scraper ²³⁾	FPM scraper	
M	D	V	A	H	W	Double- acting
F	E	B	G	Y	Z	Double- acting through rod
2	6	8	-	-	-	Duplex back-to-back
C	-	-	-	-	-	Tandem

22) If stainless steel end cover screws are selected, the piston rod nuts are also supplied in stainless steel.

23) For dry rod operation.

Operation with a dry piston rod

The seal system for operation with a dry piston rod (HDPE scraper) is available as an option for all P1D cylinders except high and low temperature version and the hydraulic model.

Order this function by specifying letter D in position 9 (double acting cylinder) or E (double acting cylinder with through piston rod). Specify the code for the seal system in either the 15 or 20 digit part number.

1	2	3	4	5	6	7	8	9	10	11	12	13	14	15
P	1	D	-	S	0	8	0	D	S	-	0	2	0	0

Cylinder version		End cover screws						Function
		Standard			Stainless steel ²²⁾			
		Std scraper	HDPE scraper ²³⁾	FPM scraper	Std scraper	HDPE scraper ²³⁾	FPM scraper	
S	Standard	M	D	V	A	H	W	Double- acting
C	Clean	F	E	B	G	Y	Z	Double- acting through rod
F	Flexible Porting	2	6	8	-	-	-	Duplex back-to-back
T	Tie-Rod	C	-	-	-	-	-	Tandem

22) If stainless steel end cover screws are selected, the piston rod nuts are also supplied in stainless steel.

23) For dry rod operation.

Example of seal system for dry rod

P1D-S040DS-0200

P1D Standard cylinder with seal system for dry operation.

P1D-C050DS-0250TERN6

P1D Clean cylinder with seal system for dry operation, stainless steel swivel rod eye, clevis bracket MP4, two factory-fitted electronic sensors, 24 VDC, PNP type, 3 m cable, cable exit at rear end cover, factory-fitted push-in fittings (Prestolok, nickel plated brass) of low elbow type for 6 mm tube. Four sealing plugs for unused end cover screws are enclosed.

P1D-C063DSC0320DMSN6

P1D Clean cylinder with seal system for dry operation, two push-in low elbow fittings placed at rear end cover for 6 mm tube, stainless steel clevis, combination of clevis bracket GA + swivel eye bracket installed on rear end cover, two factory-fitted electronic sensors, 24 VDC, PNP type, 8 mm connector (1 m cable), cable exit at rear end cover. Four sealing plugs for unused end cover screws are enclosed.

P1D Clean with built-in sensor

The entirely new P1D Clean with built-in sensors has a 20-digit part number to define all functions. Cylinder version P1D Clean is selected by putting the letter C in position 5 and the sensors are selected in position 18. These two positions determine the design of each P1D Clean cylinder. If required, the piston rod

and cylinder mountings, piston rod thread and fittings or speed controls can be selected in positions 16, 17, 19 and 20 to obtain a complete working unit. You can also specify the code for none of these options. But please remember that a code must be specified in all positions 16 – 20.

1	2	3	4	5	6	7	8	9	10	11	12	13	14	15	16	17	18	19	20
P	1	D	-	C	0	5	0	M	S	-	0	3	2	0	N	N	C	N	N

Cylinder version	
S	Standard
C	Clean ²⁾
F	Flexible Porting
T	Tie-Rod

Factory-fitted sensors			
Front end or left ¹¹⁾	Rear end or right ¹¹⁾	Front and rear end	Cable exit
F	R	-	2 sensors 24 VDC PNP, 3 m cable
G	H	-	2 sensors 24 VDC PNP, 10 m cable
C	S	-	2 sensors 24 VDC PNP, 8 mm connector, 1 m cable ²¹⁾
K	L	-	2 sensors Reed type, 3 m cable
T	V	-	2 sensors Reed type, 10 m cable
M	Q	-	2 sensors Reed type, 8 mm connector, 1 m cable ²¹⁾
-	-	3	3 sensors 24 VDC PNP, 8 mm connector, 1 m cable ²¹⁾
-	-	Z	3 sensors Reed type, 8 mm connector, 1 m cable ²¹⁾
-	-	4	4 sensors 24 VDC PNP, 8 mm connector, 1 m cable ²¹⁾
-	-	W	4 sensors Reed type, 8 mm connector, 1 m cable ²¹⁾
6 ¹²⁾	7 ¹³⁾	8 ¹⁴⁾	No factory-fitted sensors P1D Clean
N			No sensors P1D (excl. P1D Clean)

2) P1D Clean without sensor function, see page 37.

11) Left and right valid for P1D Standard and P1D Tie-Rod seen from behind with the ports on top. The sensors can only be mounted on the left for P1D Flexible Porting.

12) No factory-fitted sensors, but prepared for cable exit in the front end (max. 2 sensors).

13) No factory-fitted sensors, but prepared for cable exit in the rear end (max. 2 sensors).

14) No factory-fitted sensors, but prepared for cable exit in both ends (max. 4 sensors).

21) Due to the sensor positions, the cable length (1 m) could limit the stroke of the P1D Clean cylinders.

Example of P1D Clean

P1D-C032MS-0200NNC NN P1D Clean cylinder with two electronic sensors, PNP type, with 8 mm connector, cable exit at front end cover, 4 sealing plugs for end cover screws are enclosed.

P1D-C050MS-0160TNH NN P1D Clean cylinder with two electronic sensors, PNP type, with 10 m cable, cable exit at rear end cover, swivel rod eye in stainless steel, 4 sealing plugs for end cover screws are enclosed.

P1D-C080MS-0250-3BM NN P1D Clean cylinder with two reed sensors, with 8 mm connector, cable connection at front end cover, stainless steel clevis, flange on rear end cover, sealing plugs installed in unused end cover screws.

P1D-C125MS-04004T3 NN P1D Clean cylinder with three electronic sensors, PNP type, with 8 mm connector, cable exit at both front and rear end cover (1 cable front, 2 cables rear – can be moved to inverted configuration), extra stainless steel piston rod nut, clevis bracket MP2 on rear end cover, plugs installed in unused end cover screws.

P1D-C040MS-0320RH NN P1D Clean cylinder with four electronic sensors, PNP type, with 8 mm connector, cable exit at both front and rear end cover (2 cables in each end cover), flange mounted trunnion on front end cover, sealing plugs installed in unused end cover screws.

P1D Clean

The order numbers on this page refer to P1D Clean with two built-in electronic sensors, factory-fitted in the cylinder end positions, with cable exit at the front end cover. See the order code key to select other sensors and other location of the cable exit.



P1D Clean with electronic sensors 24 VDC, PNP, 1 m cable with 8 mm connector

Double acting

Cyl. bore mm	Stroke mm	Order code
32	25	P1D-C032MS-0025NNCNN
	40	P1D-C032MS-0040NNCNN
	50	P1D-C032MS-0050NNCNN
	80	P1D-C032MS-0080NNCNN
	100	P1D-C032MS-0100NNCNN
	125	P1D-C032MS-0125NNCNN
	160	P1D-C032MS-0160NNCNN
	200	P1D-C032MS-0200NNCNN
	250	P1D-C032MS-0250NNCNN
	320	P1D-C032MS-0320NNCNN
	400	P1D-C032MS-0400NNCNN
Conn. G1/8	500	P1D-C032MS-0500NNCNN
40	25	P1D-C040MS-0025NNCNN
	40	P1D-C040MS-0040NNCNN
	50	P1D-C040MS-0050NNCNN
	80	P1D-C040MS-0080NNCNN
	100	P1D-C040MS-0100NNCNN
	125	P1D-C040MS-0125NNCNN
	160	P1D-C040MS-0160NNCNN
	200	P1D-C040MS-0200NNCNN
	250	P1D-C040MS-0250NNCNN
	320	P1D-C040MS-0320NNCNN
	400	P1D-C040MS-0400NNCNN
Conn. G1/4	500	P1D-C040MS-0500NNCNN
50	25	P1D-C050MS-0025NNCNN
	40	P1D-C050MS-0040NNCNN
	50	P1D-C050MS-0050NNCNN
	80	P1D-C050MS-0080NNCNN
	100	P1D-C050MS-0100NNCNN
	125	P1D-C050MS-0125NNCNN
	160	P1D-C050MS-0160NNCNN
	200	P1D-C050MS-0200NNCNN
	250	P1D-C050MS-0250NNCNN
	320	P1D-C050MS-0320NNCNN
	400	P1D-C050MS-0400NNCNN
Conn. G1/4	500	P1D-C050MS-0500NNCNN
63	25	P1D-C063MS-0025NNCNN
	40	P1D-C063MS-0040NNCNN
	50	P1D-C063MS-0050NNCNN
	80	P1D-C063MS-0080NNCNN
	100	P1D-C063MS-0100NNCNN
	125	P1D-C063MS-0125NNCNN
	160	P1D-C063MS-0160NNCNN
	200	P1D-C063MS-0200NNCNN
	250	P1D-C063MS-0250NNCNN
	320	P1D-C063MS-0320NNCNN
	400	P1D-C063MS-0400NNCNN
Conn. G3/8	500	P1D-C063MS-0500NNCNN

Cyl. bore mm	Stroke mm	Order code
80	25	P1D-S080MS-0025NNCNN
	40	P1D-C080MS-0040NNCNN
	50	P1D-C080MS-0050NNCNN
	80	P1D-C080MS-0080NNCNN
	100	P1D-C080MS-0100NNCNN
	125	P1D-C080MS-0125NNCNN
	160	P1D-C080MS-0160NNCNN
	200	P1D-C080MS-0200NNCNN
	250	P1D-C080MS-0250NNCNN
	320	P1D-C080MS-0320NNCNN
	400	P1D-C080MS-0400NNCNN
Conn. G3/8	500	P1D-C080MS-0500NNCNN
100	25	P1D-C100MS-0025NNCNN
	40	P1D-C100MS-0040NNCNN
	50	P1D-C100MS-0050NNCNN
	80	P1D-C100MS-0080NNCNN
	100	P1D-C100MS-0100NNCNN
	125	P1D-C100MS-0125NNCNN
	160	P1D-C100MS-0160NNCNN
	200	P1D-C100MS-0200NNCNN
	250	P1D-C100MS-0250NNCNN
	320	P1D-C100MS-0320NNCNN
	400	P1D-C100MS-0400NNCNN
Conn. G1/2	500	P1D-C100MS-0500NNCNN
125	25	P1D-C125MS-0025NNCNN
	40	P1D-C125MS-0040NNCNN
	50	P1D-C125MS-0050NNCNN
	80	P1D-C125MS-0080NNCNN
	100	P1D-C125MS-0100NNCNN
	125	P1D-C125MS-0125NNCNN
	160	P1D-C125MS-0160NNCNN
	200	P1D-C125MS-0200NNCNN
	250	P1D-C125MS-0250NNCNN
	320	P1D-C125MS-0320NNCNN
	400	P1D-C125MS-0400NNCNN
Conn. G1/2	500	P1D-C125MS-0500NNCNN

The cylinders are supplied complete with one stainless steel piston rod nut and 4 sealing plugs to be used in the unused end cover screws.

P1D Clean

The order numbers on this page refer to P1D Clean with two built-in reed sensors, factory-fitted in the cylinder end positions, with cable exit at the front end cover. See the order code key to select other sensors and other location of the cable exit.



P1D Clean with Reed sensors, 1 m cable with 8 mm connector

Double acting

Cyl. bore mm	Stroke mm	Order code	
32	25	P1D-C032MS-0025NNMNN	
	40	P1D-C032MS-0040NNMNN	
	50	P1D-C032MS-0050NNMNN	
	80	P1D-C032MS-0080NNMNN	
	100	P1D-C032MS-0100NNMNN	
	125	P1D-C032MS-0125NNMNN	
	160	P1D-C032MS-0160NNMNN	
	200	P1D-C032MS-0200NNMNN	
	250	P1D-C032MS-0250NNMNN	
	320	P1D-C032MS-0320NNMNN	
Conn. G1/8	400	P1D-C032MS-0400NNMNN	
	500	P1D-C032MS-0500NNMNN	
	40	25	P1D-C040MS-0025NNMNN
		40	P1D-C040MS-0040NNMNN
		50	P1D-C040MS-0050NNMNN
		80	P1D-C040MS-0080NNMNN
		100	P1D-C040MS-0100NNMNN
		125	P1D-C040MS-0125NNMNN
		160	P1D-C040MS-0160NNMNN
		200	P1D-C040MS-0200NNMNN
250		P1D-C040MS-0250NNMNN	
320		P1D-C040MS-0320NNMNN	
Conn. G1/4	400	P1D-C040MS-0400NNMNN	
	500	P1D-C040MS-0500NNMNN	
	50	25	P1D-C050MS-0025NNMNN
		40	P1D-C050MS-0040NNMNN
		50	P1D-C050MS-0050NNMNN
		80	P1D-C050MS-0080NNMNN
		100	P1D-C050MS-0100NNMNN
		125	P1D-C050MS-0125NNMNN
		160	P1D-C050MS-0160NNMNN
		200	P1D-C050MS-0200NNMNN
250		P1D-C050MS-0250NNMNN	
320		P1D-C050MS-0320NNMNN	
Conn. G1/4	400	P1D-C050MS-0400NNMNN	
	500	P1D-C050MS-0500NNMNN	
	63	25	P1D-C063MS-0025NNMNN
		40	P1D-C063MS-0040NNMNN
		50	P1D-C063MS-0050NNMNN
		80	P1D-C063MS-0080NNMNN
		100	P1D-C063MS-0100NNMNN
		125	P1D-C063MS-0125NNMNN
		160	P1D-C063MS-0160NNMNN
		200	P1D-C063MS-0200NNMNN
250		P1D-C063MS-0250NNMNN	
320		P1D-C063MS-0320NNMNN	
Conn. G3/8	400	P1D-C063MS-0400NNMNN	
	500	P1D-C063MS-0500NNMNN	

Cyl. bore mm	Stroke mm	Order code	
80	25	P1D-S080MS-0025NNMNN	
	40	P1D-C080MS-0040NNMNN	
	50	P1D-C080MS-0050NNMNN	
	80	P1D-C080MS-0080NNMNN	
	100	P1D-C080MS-0100NNMNN	
	125	P1D-C080MS-0125NNMNN	
	160	P1D-C080MS-0160NNMNN	
	200	P1D-C080MS-0200NNMNN	
	250	P1D-C080MS-0250NNMNN	
	320	P1D-C080MS-0320NNMNN	
Conn. G3/8	400	P1D-C080MS-0400NNMNN	
	500	P1D-C080MS-0500NNMNN	
	100	25	P1D-C100MS-0025NNMNN
		40	P1D-C100MS-0040NNMNN
		50	P1D-C100MS-0050NNMNN
		80	P1D-C100MS-0080NNMNN
		100	P1D-C100MS-0100NNMNN
		125	P1D-C100MS-0125NNMNN
		160	P1D-C100MS-0160NNMNN
		200	P1D-C100MS-0200NNMNN
250		P1D-C100MS-0250NNMNN	
320		P1D-C100MS-0320NNMNN	
Conn. G1/2	400	P1D-C100MS-0400NNMNN	
	500	P1D-C100MS-0500NNMNN	
	125	25	P1D-C125MS-0025NNMNN
		40	P1D-C125MS-0040NNMNN
		50	P1D-C125MS-0050NNMNN
		80	P1D-C125MS-0080NNMNN
		100	P1D-C125MS-0100NNMNN
		125	P1D-C125MS-0125NNMNN
		160	P1D-C125MS-0160NNMNN
		200	P1D-C125MS-0200NNMNN
250		P1D-C125MS-0250NNMNN	
320		P1D-C125MS-0320NNMNN	
Conn. G1/2	400	P1D-C125MS-0400NNMNN	
	500	P1D-C125MS-0500NNMNN	

The cylinders are supplied complete with one stainless steel piston rod nut and 4 sealing plugs to be used in the unused end cover screws.

P1D Clean without sensor function

The only exception from the 20-digit part number is one version of P1D Clean which has a 15-digit order number. This version is a permanently sealed P1D Clean with no facility for installing sensors. The exterior of this cylinder is characterised by not having the big transparent cover, it has instead two short covers with a transparent moulding between. The cylinder has a very clean design and is intended for applications where no sensors are used.

The P1D without the sensor function can of course be combined with other equipment and functions by using a 20-digit order number. But please note that the letter N must always be used in position 18.



1	2	3	4	5	6	7	8	9	10	11	12	13	14	15
P	1	D	-	C	0	4	0	M	S	-	0	2	5	0

Cylinder version	
S	Standard
C	Clean
F	Flexible Porting
T	Tie-Rod

P1D Clean without sensor function is defined by the letter C in position 5 and the 15-digit order number

Double acting

Cyl. bore mm	Stroke mm	Order code
32	25	P1D-C032MS-0025
	40	P1D-C032MS-0040
	50	P1D-C032MS-0050
	80	P1D-C032MS-0080
	100	P1D-C032MS-0100
	125	P1D-C032MS-0125
	160	P1D-C032MS-0160
	200	P1D-C032MS-0200
	250	P1D-C032MS-0250
	320	P1D-C032MS-0320
Conn. G1/8	400	P1D-C032MS-0400
	500	P1D-C032MS-0500
40	25	P1D-C040MS-0025
	40	P1D-C040MS-0040
	50	P1D-C040MS-0050
	80	P1D-C040MS-0080
	100	P1D-C040MS-0100
	125	P1D-C040MS-0125
	160	P1D-C040MS-0160
	200	P1D-C040MS-0200
	250	P1D-C040MS-0250
	320	P1D-C040MS-0320
Conn. G1/4	400	P1D-C040MS-0400
	500	P1D-C040MS-0500
50	25	P1D-C050MS-0025
	40	P1D-C050MS-0040
	50	P1D-C050MS-0050
	80	P1D-C050MS-0080
	100	P1D-C050MS-0100
	125	P1D-C050MS-0125
	160	P1D-C050MS-0160
	200	P1D-C050MS-0200
	250	P1D-C050MS-0250
	320	P1D-C050MS-0320
Conn. G1/4	400	P1D-C050MS-0400
	500	P1D-C050MS-0500

Cyl. bore mm	Stroke mm	Order code
63	25	P1D-C063MS-0025
	40	P1D-C063MS-0040
	50	P1D-C063MS-0050
	80	P1D-C063MS-0080
	100	P1D-C063MS-0100
	125	P1D-C063MS-0125
	160	P1D-C063MS-0160
	200	P1D-C063MS-0200
	250	P1D-C063MS-0250
	320	P1D-C063MS-0320
Conn. G3/8	400	P1D-C063MS-0400
	500	P1D-C063MS-0500
80	25	P1D-C080MS-0025
	40	P1D-C080MS-0040
	50	P1D-C080MS-0050
	80	P1D-C080MS-0080
	100	P1D-C080MS-0100
	125	P1D-C080MS-0125
	160	P1D-C080MS-0160
	200	P1D-C080MS-0200
	250	P1D-C080MS-0250
	320	P1D-C080MS-0320
Conn. G3/8	400	P1D-C080MS-0400
	500	P1D-C080MS-0500
100	25	P1D-C100MS-0025
	40	P1D-C100MS-0040
	50	P1D-C100MS-0050
	80	P1D-C100MS-0080
	100	P1D-C100MS-0100
	125	P1D-C100MS-0125
	160	P1D-C100MS-0160
	200	P1D-C100MS-0200
	250	P1D-C100MS-0250
	320	P1D-C100MS-0320
Conn. G1/2	400	P1D-C100MS-0400
	500	P1D-C100MS-0500

Cyl. bore mm	Stroke mm	Order code
125	25	P1D-C125MS-0025
	40	P1D-C125MS-0040
	50	P1D-C125MS-0050
	80	P1D-C125MS-0080
	100	P1D-C125MS-0100
	125	P1D-C125MS-0125
	160	P1D-C125MS-0160
	200	P1D-C125MS-0200
	250	P1D-C125MS-0250
	320	P1D-C125MS-0320
Conn. G1/2	400	P1D-C125MS-0400
	500	P1D-C125MS-0500

The cylinders are supplied complete with one stainless steel piston rod nut and 4 sealing plugs to be used in the unused end cover screws.

P1D Flexible Porting

The P1D Flexible Porting with both cylinder ports in one end cover has a 20-digit part number. Position 11 is used to select the position of the cylinder ports (all cylinders with one connection in each end cover have a dash in this position). Please note that cylinder bores 32-63 mm only have the push-in fitting design and 80-125 mm is only available with threaded connections. Position 20 is used to specify the type of push-in fittings (low elbow or straight fitting) and tube dimension (4 or 6

mm for Ø32 and 40, and 8 or 10 mm for Ø50 and 63). For cylinder bores Ø32-63 mm, the fittings are made of plastics material for Flexible Porting cylinders (nickel plated brass on all other P1D cylinders). These four smallest bores can not be equipped with speed controls. For cylinder bores Ø80-125 mm, position 20 is used to select the speed controls, fittings (Prestolok, nickel plated brass) or none (code N).

1	2	3	4	5	6	7	8	9	10	11	12	13	14	15	16	17	18	19	20	
P	1	D	-	F	0	6	3	M	S	B	0	3	2	0	N	N	N	N	N	0

Cylinder version	
S	Standard
C	Clean
F	Flexible Porting
T	Tie-Rod

Cylinder ports			
Front & rear	Both front	Both rear	Port location
-	H ³⁾	J ³⁾	G threads, BSPP (Ø80-125 mm)
-	B ⁴⁾	C ⁴⁾	Push-in , metric (Ø32-63 mm)

Speed controls or fittings for tube dimension	
Speed controls ¹⁷⁾ Series PTF4PB ¹⁶⁾	
X	in both ends for tube 4 mm
Y	in both ends for tube 6 mm
Z	in both ends for tube 8 mm
P	in both ends for tube 10 mm
R	in both ends for tube 12 mm
Push-in fitting, elbow type for:	
4	Tube dimension 4 mm
6	Tube dimension 6 mm
8	Tube dimension 8 mm
0	Tube dimension 10 mm
2	Tube dimension 12 mm
Push-in fitting, straight type for:	
1	Tube dimension 4 mm
3	Tube dimension 6 mm
5	Tube dimension 8 mm
7	Tube dimension 10 mm
9	Tube dimension 12 mm
N	None

3) Only for P1D-F bore 80-125 mm. Select optional fittings in position 20.

4) Only for P1D-F bore 32-63 mm. Select fittings in position 20.

16) P1D Clean cylinders have factory installed nickel plated versions of the PTF series.

17) Not available for P1D Flexible Porting bore 32-63 mm.

Available fittings and speed controls for P1D Flexible Porting			
Cyl. bore	Speed controls for tube	Elbow fitting for tube	Straight fitting for tube
32, 40	not available	4, 6	4, 6
50, 63	not available	8, 10	8, 10
80	8, 10, 12	8, 10, 12	8, 10, 12
100, 125	12	12	10, 12

Examples of P1D Flexible Porting

P1D-F050MSB0160SMKN8 Flexible Porting cylinder with two plug-in low elbow fittings for 8 mm tube, placed at front end cover, zinc plated steel swivel rod eye, combination clevis bracket GA and swivel eye bracket installed on rear end cover, two factory-fitted reed sensors with 3 m cable.

P1D-F080MSH0500BFCN Flexible Porting cylinder with two threaded connections in front end cover, zinc plated steel clevis, foot brackets, two factory-fitted electronic sensors, PNP type, with 8 mm connector (0.3 m cable), sealing plugs installed in unused end cover screws.

P1D-F032MSB0250NNNN6 Flexible Porting cylinder with two push-in elbow fittings for 6 mm tube, placed at front end cover.

P1D-F063MSC0400NNNN7 Flexible Porting cylinder with two straight push-in fittings for 10 mm tube, placed at rear end cover (only possible to choose 8 or 10 mm for cylinder bore 50 and 63 mm).

P1D-F125MSJ0600NNNNN Flexible Porting cylinder with two threaded connections in rear end cover.

P1D Flexible Porting

The order codes on this page refer to P1D Flexible Porting with both cylinder ports in the front end cover and with factory-fitted push-in elbow fittings. For Ø32-63 mm, the fittings are made of plastic, whereas Ø80-125 mm can be ordered with threaded ports only or with push-in Prestolok nickel plated brass fittings. See the order key to select fittings.



P1D Flexible Porting

Double acting

Cyl. bore mm	Stroke mm	Order code
32	25	P1D-F032MSB0025NNNN6
	40	P1D-F032MSB0040NNNN6
	50	P1D-F032MSB0050NNNN6
	80	P1D-F032MSB0080NNNN6
	100	P1D-F032MSB0100NNNN6
	125	P1D-F032MSB0125NNNN6
	160	P1D-F032MSB0160NNNN6
	200	P1D-F032MSB0200NNNN6
	250	P1D-F032MSB0250NNNN6
	320	P1D-F032MSB0320NNNN6
	400	P1D-F032MSB0400NNNN6
500	P1D-F032MSB0500NNNN6	
Push-in elbow 6 mm		
40	25	P1D-F040MSB0025NNNN6
	40	P1D-F040MSB0040NNNN6
	50	P1D-F040MSB0050NNNN6
	80	P1D-F040MSB0080NNNN6
	100	P1D-F040MSB0100NNNN6
	125	P1D-F040MSB0125NNNN6
	160	P1D-F040MSB0160NNNN6
	200	P1D-F040MSB0200NNNN6
	250	P1D-F040MSB0250NNNN6
	320	P1D-F040MSB0320NNNN6
	400	P1D-F040MSB0400NNNN6
500	P1D-F040MSB0500NNNN6	
Push-in elbow 6 mm		
50	25	P1D-F050MSB0025NNNN0
	40	P1D-F050MSB0040NNNN0
	50	P1D-F050MSB0050NNNN0
	80	P1D-F050MSB0080NNNN0
	100	P1D-F050MSB0100NNNN0
	125	P1D-F050MSB0125NNNN0
	160	P1D-F050MSB0160NNNN0
	200	P1D-F050MSB0200NNNN0
	250	P1D-F050MSB0250NNNN0
	320	P1D-F050MSB0320NNNN0
	400	P1D-F050MSB0400NNNN0
500	P1D-F050MSB0500NNNN0	
Push-in elbow 10 mm		
63	25	P1D-F063MSB0025NNNN0
	40	P1D-F063MSB0040NNNN0
	50	P1D-F063MSB0050NNNN0
	80	P1D-F063MSB0080NNNN0
	100	P1D-F063MSB0100NNNN0
	125	P1D-F063MSB0125NNNN0
	160	P1D-F063MSB0160NNNN0
	200	P1D-F063MSB0200NNNN0
	250	P1D-F063MSB0250NNNN0
	320	P1D-F063MSB0320NNNN0
	400	P1D-F063MSB0400NNNN0
500	P1D-F063MSB0500NNNN0	
Push-in elbow 10 mm		

P1D Flexible Porting

Double acting

Cyl. bore mm	Stroke mm	Order code
80	25	P1D-S080MSH0025NNNN0
	40	P1D-F080MSH0040NNNN0
	50	P1D-F080MSH0050NNNN0
	80	P1D-F080MSH0080NNNN0
	100	P1D-F080MSH0100NNNN0
	125	P1D-F080MSH0125NNNN0
	160	P1D-F080MSH0160NNNN0
	200	P1D-F080MSH0200NNNN0
	250	P1D-F080MSH0250NNNN0
	320	P1D-F080MSH0320NNNN0
	400	P1D-F080MSH0400NNNN0
500	P1D-F080MSH0500NNNN0	
Push-in elbow 10 mm		
100	25	P1D-F100MSH0025NNNN2
	40	P1D-F100MSH0040NNNN2
	50	P1D-F100MSH0050NNNN2
	80	P1D-F100MSH0080NNNN2
	100	P1D-F100MSH0100NNNN2
	125	P1D-F100MSH0125NNNN2
	160	P1D-F100MSH0160NNNN2
	200	P1D-F100MSH0200NNNN2
	250	P1D-F100MSH0250NNNN2
	320	P1D-F100MSH0320NNNN2
	400	P1D-F100MSH0400NNNN2
500	P1D-F100MSH0500NNNN2	
Push-in elbow 12 mm		
125	25	P1D-F125MSH0025NNNN2
	40	P1D-F125MSH0040NNNN2
	50	P1D-F125MSH0050NNNN2
	80	P1D-F125MSH0080NNNN2
	100	P1D-F125MSH0100NNNN2
	125	P1D-F125MSH0125NNNN2
	160	P1D-F125MSH0160NNNN2
	200	P1D-F125MSH0200NNNN2
	250	P1D-F125MSH0250NNNN2
	320	P1D-F125MSH0320NNNN2
	400	P1D-F125MSH0400NNNN2
500	P1D-F125MSH0500NNNN2	
Push-in elbow 12 mm		

The cylinders are supplied complete with one zinc plated steel piston rod nut.

Combine P1D Clean and P1D Flexible Porting

All Clean cylinders can be combined with the connections in the front or rear end cover in accordance with the Flexible Porting design. Specify cylinder version C in position 5, position of connection ports in position 11 (codes H, J, B or C), choice of built-in sensors in position 18 and type of fitting and tube

dimension in position 20. Naturally, the cylinder can be equipped with piston rod fittings and cylinder mountings in positions 16 and 17 if required. As with all clean cylinders a set of 4 sealing plugs is enclosed for installation in unused end cover screws.

1	2	3	4	5	6	7	8	9	10	11	12	13	14	15	16	17	18	19	20
P	1	D	-	C	0	5	0	M	S	B	0	3	2	0	N	N	C	N	8

Cylinder version	
S	Standard
C	Clean ²⁾
F	Flexible Porting
T	Tie-Rod

Cylinder ports		
Front & rear	Both front	Both rear
Port location		
-	H ³⁾	J ³⁾
G threads, BSPP (Ø80-125 mm)		
-	B ⁴⁾	C ⁴⁾
Push-in , metric (Ø32-63 mm)		

Factory-fitted sensors		
Front end or left ¹¹⁾	Rear end or right ¹¹⁾	Front and rear end
Cable exit		
F	R	-
2 sensors 24 VDC PNP, 3 m cable		
G	H	-
2 sensors 24 VDC PNP, 10 m cable		
C	S	-
2 sensors 24 VDC PNP, 8 mm connector, 1 m cable ²¹⁾		
K	L	-
2 sensors Reed type, 3 m cable		
T	V	-
2 sensors Reed type, 10 m cable		
M	Q	-
2 sensors Reed type, 8 mm connector, 1 m cable ²¹⁾		
-	-	3
3 sensors 24 VDC PNP, 8 mm connector, 1 m cable ²¹⁾		
-	-	Z
3 sensors Reed type, 8 mm connector, 1 m cable ²¹⁾		
-	-	4
4 sensors 24 VDC PNP, 8 mm connector, 1 m cable ²¹⁾		
-	-	W
4 sensors Reed type, 8 mm connector, 1 m cable ²¹⁾		
6 ¹²⁾	7 ¹³⁾	8 ¹⁴⁾
No factory-fitted sensors P1D Clean		
N		
No sensors P1D (excl. P1D Clean)		

Speed controls or fittings for tube dimension	
Speed controls ¹⁷⁾ Series PTF 4/8PB ¹⁶⁾	
X	in both ends for tube 4 mm ¹⁵⁾
Y	in both ends for tube 6 mm ¹⁵⁾
Z	in both ends for tube 8 mm ¹⁵⁾
P	in both ends for tube 10 mm ¹⁵⁾
R	in both ends for tube 12 mm ¹⁵⁾
Push-in fitting, elbow type for:	
4	Tube dimension 4 mm ¹⁵⁾
6	Tube dimension 6 mm ¹⁵⁾
8	Tube dimension 8 mm ¹⁵⁾
0	Tube dimension 10 mm ¹⁵⁾
2	Tube dimension 12 mm ¹⁵⁾
Push-in fitting, straight type for:	
1	Tube dimension 4 mm ¹⁵⁾
3	Tube dimension 6 mm ¹⁵⁾
5	Tube dimension 8 mm ¹⁵⁾
7	Tube dimension 10 mm ¹⁵⁾
9	Tube dimension 12 mm ¹⁵⁾
N	None

- 2) P1D Clean without sensor function, see page 37.
- 3) Only for P1D-F bore 80-125 mm. Select optional fittings in position 20.
- 4) Only for P1D-F bore 32-63 mm. Select fittings in position 20.
- 11) Left and right valid for P1D Standard and P1D Tie-Rod seen from behind with the ports on top. The sensors can only be mounted on the left for P1D Flexible Porting.
- 12) No factory-fitted sensors, but prepared for cable exit in the front end (max. 2 sensors).
- 13) No factory-fitted sensors, but prepared for cable exit in the rear end (max. 2 sensors).

- 14) No factory-fitted sensors, but prepared for cable exit in both ends (max. 4 sensors).
- 15) To choose speed control and couplings, please refer to page 23 for P1D Standard and page 32 for P1D Flexible Porting.
- 16) P1D Clean cylinders have factory fitted nickel plated versions of the PTF series.
- 17) Not available with P1D Flexible Porting bore 32-63 mm.
- 21) Due to the sensor positions, the cable length (1 m) could limit the stroke of the P1D Clean cylinders.

Examples of P1D Clean in combination with Flexible Porting

P1D-C032MSB0200NNSN6 P1D Clean cylinder with two push-in elbow fittings for 6 mm tube, placed at front end cover, two factory-fitted electronic sensors, PNP type, with 8 mm connector, cable exit at rear end cover, 4 sealing plugs for end cover screws are enclosed.

P1D-C080MSJ0500AN3N0 P1D Clean cylinder with two threaded connections in rear end cover, factory-fitted push-in elbow fittings (Prestolok, nickel plated brass) for 10 mm tube in both connections, three factory-fitted electronic sensors, PNP type, with 8 mm connector, cable exit in both front and rear end covers, zinc plated steel swivel rod eye, 4 sealing plugs are installed in unused end cover screws.



P1D complete working unit

P1D Standard can be ordered with a factory-fitted valve and tubing. The valve series is the robust and compact Viking series, with product code P2L-A (for cylinder bores 32-63), P2L-B (for cylinder bores 80-100) and P2L-D (for cylinder bore 125). This valve series was specially designed for harsh environments and a long service life. The valve is securely fitted to a fixing plate bolted onto the case of the cylinder. The unit is delivered complete with valve, Prestolok push-in connection in nickel plated brass, and hosing. The valve has built-in silencers (Siflow for speed regulation), and electrically-operated versions have solenoid valves (P2E with spring-loaded manual override) and a cable head with LED and spark dispersion. The supply voltage is 24V for AC as well as DC versions. This UC (Universal Current) is possible because of a built-in rectifier in the cable head, allowing the use of direct current and alternating current for actuation. Of course, the entire range of P1D accessories can also be used for the P1D with built-in valve, and cylinders can be ordered with factory-fitted accessories and sensors.

Fast response

The large flow capacity of the valve and the short distance between the valve and the cylinder ports mean that the working unit operates quickly (short actuation time and with minimal flow restriction).

No maintenance and easy to service

The working unit is built from standard components. The cylinders and the valves are designed to be used without supplementary lubrication.

Wide range of applications

The complete working unit can be used in silo applications, for operating flaps and valves, in sawmills and in many similar installations in which the cylinders are scattered or the fast actuation is important. The unit with the valve installed is compact, so it can also be used in small spaces.

Range of solenoid valve voltages

The solenoid valves are available in the standard voltages, for example;

24 V UC (24 V AC/DC, Universal Current)
115 V/50 Hz, 120 V/60 Hz
230 V/50 Hz, 240 V/60 Hz

Technical data

Working pressure	max 10 bar	
Working media	dry filtered compressed air.	
	Please refer to page 14.	
Working temperature:	-20 °C to +70 °C (-15 °C to +60 °C with solenoid valve)	
Flow, P2L-A, acc. to ISO 6358	Qn = 760 NI/min	
Flow, P2L-B, acc. to ISO 6358	Qn = 1020 NI/min	
Flow, P2L-D, acc. to ISO 6358	Qn = 2880 NI/min	
Solenoid power consumption	Pull	Hold
P2E-KV32C1, 24 V DC	1,2 W	1,2 W
P2E-KV31C1, 24 VAC	3,5 VA	1,6 VA

Material specification

P1D cylinders	please refer to page 15.
Valves ¹⁾	
Housing and ends	Black anodised aluminium
Solenoid valves	
Housing	Polyamide
Magnet coil	Epoxy coated
Fixing plate	Anodised aluminium
Fixing screws for plate	Stainless steel
Fixing screws for valve	Zinc-coated steel
Angle connections	Nickel-coated brass
Plastic tubes	PUR

1) see also catalogue for P2L series Viking valves

Accessories

Name	Order code
Siflow silencer for P2L-A valve, G1/8	9301050901
Sintered plastic silencer for P2L-A valve, G1/8	P6M-PAB1
Siflow silencer for P2L-B valve, G1/4	9301050902
Sintered plastic silencer for P2L-B valve, G1/4	P6M-PAB2
Siflow silencer for P2L-D valve, G1/2	9301050904
Sintered plastic silencer for P2L-D valve, G1/2	P6M-PAB4
Fixing plate for Ø32 - Ø63, valve P2L-A, -B	9121742111
Fixing plate for Ø80, Ø100, valve P2L-A, -B, -D	9121742112
Fixing plate for Ø125, valve P2L-A, -B, -D	9121742113

Factory Fitted Valve

A 20-character order number is used to order the P1D Standard with factory fitted valve. Position 5 indicates the cylinder version, with the actuation type in position 11 and the valve type in position 20. Note that cylinder diameters 32-63 use valve P2L-A (1/8"), diameters 80-100 use P2L-B (1/4"), and diameter 125

uses P2L-D (1/2"). This version of the cylinder can of course be combined with factory-fitted cylinder accessories, piston rod accessories and sensors. Fixing plates for different valve sizes may be ordered separately.

1	2	3	4	5	6	7	8	9	10	11	12	13	14	15	16	17	18	19	20
P	1	D	-	V	0	5	0	M	S	1	0	3	2	0	N	N	N	N	H

Cylinder version	
V	Standard with factory fitted valve
4	Standard with lock unit and factory fitted valve

Factory fitted valve type	
0	Air actuated
1	Electrically actuated 24 V UC, LED+VDR (AC/DC Universal Current) Complete with rectifier
4	Electrically actuated 24 V UC, LED+VDR with 5 m integral cable (AC/DC Universal Current) Complete with rectifier
7	Electrically actuated 24 V UC, LED+VDR with 10 m integral cable (AC/DC Universal Current) Complete with rectifier
2	Electrically actuated 115 V/50 Hz, 120 V/60 Hz, LED+VDR
3	Electrically actuated 230 V/50 Hz, 240 V/60 Hz, LED+VDR

Valve function	
Air actuated	
A	Air-Air, 5/2
B	Air-Spring, 5/2
C	Air-Air, 5/3, closed centre position
D	Air-Air, 5/3, vented centre
E	Air-Air, 5/3, pressurised centre
Electrically actuated internal supply	
F	Elec-Elec, 5/2
H	Elec-Spring, 5/2
K	Spring-Elec*, 5/2
M	Elec-Elec, 5/3, closed centre position
Q	Elec-Elec, 5/3, vented centre
S	Elec-Elec, 5/3, pressurised centre
Electrically actuated external supply	
G	Elec-Elec, 5/2
J	Elec-Spring, 5/2
L	Spring-Elec*, 5/2

* Piston rod in extended position with unactuated valve

CAD drawings on the Internet

Our home page www.parker.com/euro_pneumatic includes the AirCad Drawing Library with 2D and 3D drawings for the main versions.

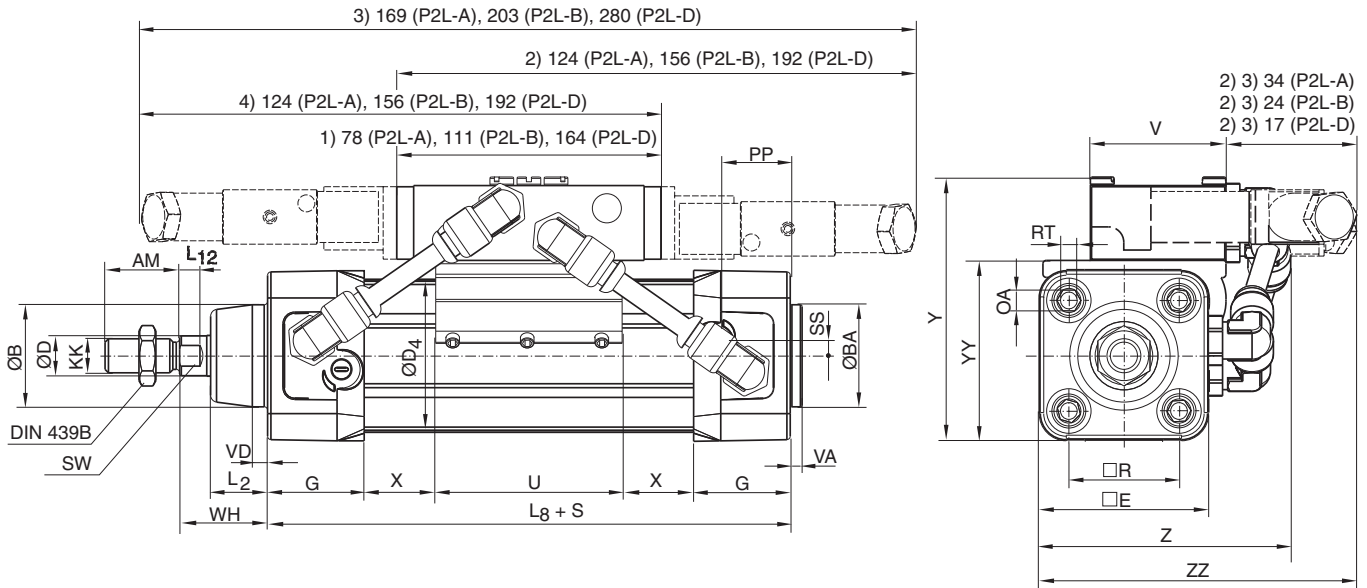

Dimensions

Cylinder dia. mm	AM mm	B mm	BA mm	BG mm	D mm	D4 mm	E mm	G mm	KK	L2 mm	L8 mm	L12 mm	OA mm
32	22	30	30	16	12	45,0	50,0	28,5	M10x1,25	16,0	94	6,0	6,0
40	24	35	35	16	16	52,0	57,4	33,0	M12x1,25	19,0	105	6,5	6,0
50	32	40	40	16	20	60,7	69,4	33,5	M16x1,5	24,0	106	8,0	8,0
63	32	45	45	16	20	71,5	82,4	39,5	M16x1,5	24,0	121	8,0	8,0
80	40	45	45	17	25	86,7	99,4	39,5	M20x1,5	30,0	128	10,0	6,0
100	40	55	55	17	25	106,7	116,0	44,5	M20x1,5	32,4	138	14,0	6,0
125	54	60	60	20	32	134,0	139,0	51,0	M27x2	45,0	160	18,0	8,0

Cylinder dia. mm	PP mm	R mm	RT	SS mm	SW mm	VA mm	VD mm	WH mm	U mm	V mm	X mm
32	21,8	32,5	M6	4,0	10	3,5	4,5	26	55	40	-9+S/2
40	21,9	38,0	M6	8,0	13	3,5	4,5	30	55	40	-8+S/2
50	23,0	46,5	M8	4,0	17	3,5	5,0	37	55	40	-8+S/2
63	27,4	56,5	M8	6,5	17	3,5	5,0	37	55	40	-6,5+S/2
80	30,5	72,0	M10	0	22	3,5	4,0	46	55	54	-2,5+S/2
100	35,8	89,0	M10	0	22	3,5	4,0	51	55	54	-2,5+S/2
125	40,5	110,0	M12	0	27	5,5	6,0	65	55	65	2+S/2

Cylinder dia. mm	Y mm	YY mm	Z mm	ZZ mm
32	80	56	80	90
40	88	64	87	96
50	102	78	96	105
63	109	85	107	116
80	136	102	132	125
100	151	117	148	140
125	185	146	183	159

S=Stroke

- 1) Air actuated 5/2 and 5/3
- 2) Electrically actuated 5/2 with spring return
- 3) Electrically actuated 5/2 and 5/3 (2 solenoid valves)
- 4) Electrically actuated 5/2 with spring return(reverse function)

P1D-L



P1D-D



P1D cylinder with piston rod locking

The P1D cylinder is available in a version with piston rod locking, allowing the piston rod to be locked in any position. The lock unit, of the air/spring actuated type, is integrated in the front end piece of the cylinder. With no signal pressure, the full force of the lock is applied to the piston rod, and the lock is released at 4 bar signal pressure. Lock units are available for P1D Standard (P1D-L) and P1D Clean (P1D-D) in bores 32-125 mm. P1D Standard can be ordered with a lock unit and a built-in valve (P1D-4). Of course, the entire range of P1D accessories can also be used for the locking cylinder, which can be ordered with factory fitted accessories, sensors and valves. However, the lock unit increases the overall length of the cylinder. Compare the dimensional diagrams on pages 22 and 47. The overall dimensions specified in the catalogue for built-in cylinder fittings, pages 52 - 60, are only correct for P1D standard versions without lock unit.

Clean and compact design

The front end piece and lock unit form an integrated block, keeping the length of the structure short. The design is easy to clean, sealed and waterproof. The exhaust air from the lock unit

can be removed by replacing the filter unit with a connector and hose. This is an advantage in terms of cleaning or when environmental factors are important.

Locking and braking.

The static locking force corresponds to 7 bar pressure. Under certain circumstances, the lock can also be used as a brake for positioning or similar applications. The maximum values set out in the graph on page 45 must not be exceeded.

Function on pressure loss

The piston rod lock can be used in all material handling systems where controlled fastening or positioning is required. The piston rod lock is also suitable for use as a pressure-loss brake for cylinders with suspended loads, for example. See lock forces. The signal air to the lock unit can be connected directly to the air system or to the supply air for the valve controlling the cylinder in question. For controlled on/off operation of the lock unit, a separate valve, with large exhaust flow capacity, is used.

Technical data

Working pressure	max 10 bar
Working media	dry filtered compressed air
Working temperature	-20 °C to +80 °C
Release pressure ¹⁾	min 4 bar ±10%

1) Signal pressure to inlet port of lock unit.

Static lock forces

Lock forces at 0 bar signal pressure to lock unit

Cylinder dia. mm	Lock force N
32	550
40	860
50	1345
63	2140
80	3450
100	5390
125	8425

Material specification, piston rod locking

Housing/end piece	Black anodised aluminium
Lock collar/piston	Hardened steel
Springs	Stainless steel
Piston rod seal Dim 32-40	UHMWPE plastic
Piston rod seal Dim 50-125	Polyurethane
O-rings	Nitrile rubber, NBR
Scraper ring	Polyurethane
Air filter	Brass/sintered bronze

Other data as for relevant base cylinder.

The cylinders are supplied with a hard chrome plated piston rod.

NOTE!

If rod guidance module is to be fitted, the piston rod must be extended to provide the same WH dimensions as for the P1D base cylinder. Please refer to page 48.

Speed [m/s]

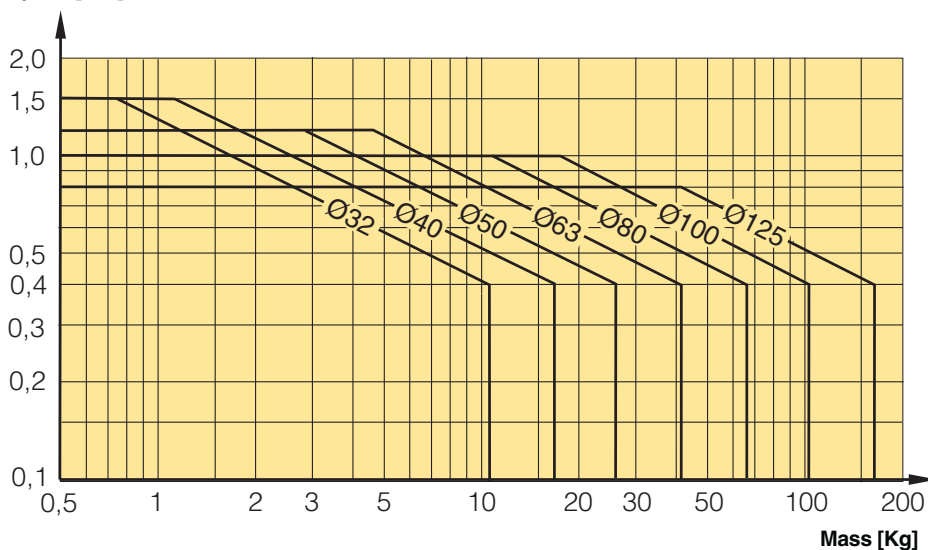

Use as a brake

The table shows the maximum values for speed and braking mass if the cylinder is used as a brake. The cylinder should not be exposed to additional compressive forces as this significantly reduces the external mass that can be braked.

We recommend system solutions as shown at the top of page 46 (Fastening in position) or similar, in which the cylinder does not act as a motor during braking. Heat is generated if the brake is used frequently, and this must be taken into account to ensure that the maximum temperature is not exceeded.

Piston rod locking

To order a cylinder with piston rod locking, position 5 should contain L (P1D Standard with lock unit), D (P1D Clean cylinder with lock unit) or 4 (P1D with factory fitted valve and lock unit). Note that the P1D with piston rod locking requires a chrome

plated piston rod or chrome plated stainless steel piston rod because of the high surface pressure. For factory-fitted cylinder accessories, sensors, etc. please refer to the complete order code key on pages 70-74.

1	2	3	4	5	6	7	8	9	10	11	12	13	14	15
P	1	D	-	L	0	8	0	M	C	-	0	2	0	0

Cylinder version

L	Standard with lock unit
D	Clean with lock unit
4	Standard with lock unit and factory fitted valve

Material		Seals
Piston rod		
Hard chrome plated steel	Hard chr. pl. stainless steel	
C	R	Standard -20 °C to +80 °C.

Fastening in position

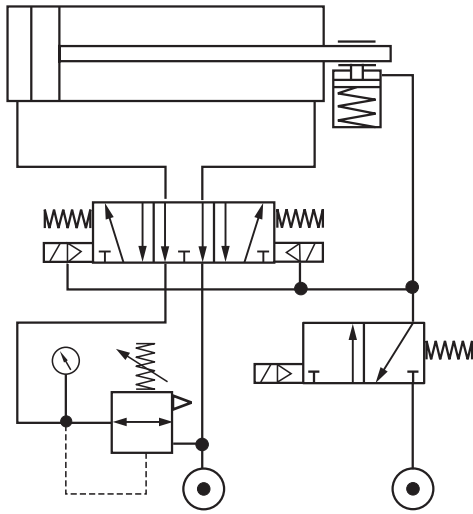

This is the optimum solution for straightforward fastening in any position, while preserving the maximum expected service life of the lock. The cylinder is supplied with compressed air via a 5/3 valve with vented centre. The valve is supplied with full pressure in port 3, port 2 is connected to the minus port on the cylinder, port 5 is supplied with a reduced pressure and port 4 is connected to the plus port on the cylinder. The reduced pressure to the cylinder plus port is to equalise the force, so that no forces can act on the lock when it is in the locked position. The solenoid valves of the 5/3 valve are supplied with compressed air from a 3/2 valve, which also supplies compressed air to release the lock. To cause the cylinder to move in either direction, the 3/2 must be actuated in order to release the lock and supply the solenoid valves with signal air, after which they can be actuated. This means that as soon as the 3/2 valve is deactuated, the lock is applied and no signal air is supplied to the solenoid valves, causing the 5/3 valve to switch to the centre position. The cylinder is now supplied by the two different pressure sources, is fully vented and no force is applied to the lock.

Function on hose rupture

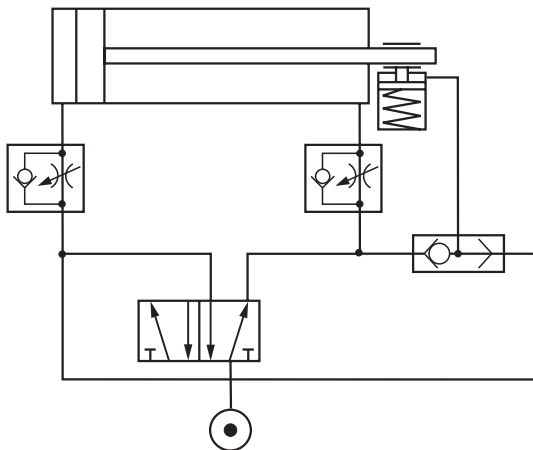

This arrangement helps to secure the piston rod if there is a pressure loss due to hose rupture. The cylinder is supplied by a 5/2 valve and the cylinder speed is controlled using flow control valves with by-pass fitted near the cylinder. A TEE piece is fitted in the pipe between the working valve and the cylinder, going to a changeover valve with air passing to the lock. In the event of a pressure loss, the pressure to the 5/2 valve ceases, as does the pressure via the changeover valve to the lock. The lock is then applied.

Function on pressure loss

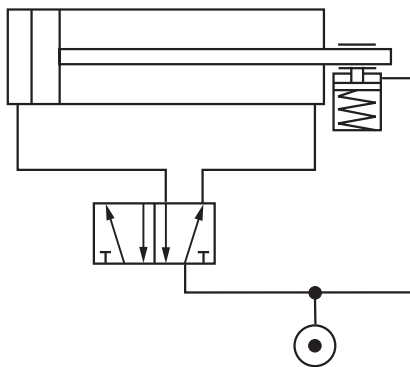

This solution is used to lock the cylinder in the event of a pressure loss in the system. A TEE piece is fitted in the pipe feeding the working valve for the cylinder. The lock on the cylinder is supplied from this TEE piece. In the event of a pressure loss, the lock is vented immediately and is applied.

CAD drawings on the Internet

Our home page www.parker.com/euro_pneumatic includes the AirCad Drawing Library with 2D and 3D drawings for the main versions.

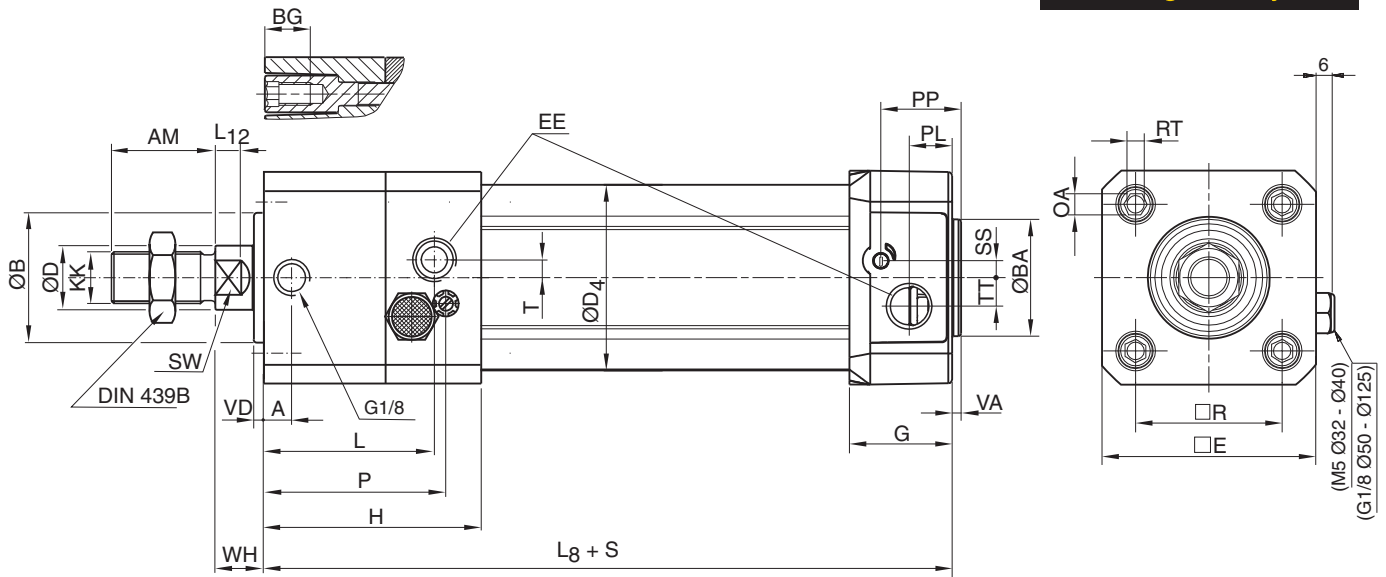

Dimensions

Cylinder dia. mm	A	AM	B	BA	BG	D	D4	E	EE	G	H	KK	L	L2
32	18,5	22	30	30	16	12	45,0	50,0	G1/8	28,5	71,0	M10x1,25	53,0	16,0
40	20,0	24	35	35	16	16	52,0	57,4	G1/4	33,0	76,5	M12x1,25	56,0	19,0
50	21,0	32	40	40	16	20	60,7	69,4	G1/4	33,5	80,0	M16x1,5	65,0	24,0
63	30,0	32	45	45	16	20	71,5	82,4	G3/8	39,5	96,0	M16x1,5	76,5	24,0
80	35,0	40	45	45	17	25	86,7	99,4	G3/8	39,5	110,0	M20x1,5	89,0	30,0
100	54,0	40	55	55	17	25	106,7	116,0	G1/2	44,5	132,0	M20x1,5	112,0	32,4
125	65,5	54	60	60	20	32	134,0	139,0	G1/2	51,0	144,5	M27x2	124,5	45,0

Cylinder dia. mm	L8	L12	OA	P	PL	PP	R	RT	SS	SW	T	TT	VA	VD	WH
32	137	6,0	6,0	63,0	13,0	21,8	32,5	M6	4,0	10	4,5	4,5	3,5	4,5	15
40	149	6,5	6,0	67,5	14,0	21,9	38,0	M6	8,0	13	3,0	5,5	3,5	4,5	16
50	153	8,0	8,0	71,0	14,0	23,0	46,5	M8	4,0	17	5,5	7,5	3,5	5,0	17
63	178	8,0	8,0	87,0	16,4	27,4	56,5	M8	6,5	17	3,0	11,0	3,5	5,0	17
80	199	10,0	6,0	101,0	16,0	30,5	72,0	M10	0	22	6,0	15,0	3,5	4,0	20
100	226	14,0	6,0	122,0	18,0	35,8	89,0	M10	0	22	6,0	20,0	3,5	4,0	20
125	254	18,0	8,0	134,5	28,0	40,5	110,0	M12	0	27	6,0	17,5	5,5	6,0	27

S=Stroke

Tolerances

Cylinder bore mm	B	BA	L ₈	L ₉	R	Stroke tolerance up to stroke 500 mm	Stroke tolerance for stroke over 500 mm
32	d11	d11	±0,4	±2	±0,5	+0,3/+2,0	+0,3/+3,0
40	d11	d11	±0,7	±2	±0,5	+0,3/+2,0	+0,3/+3,0
50	d11	d11	±0,7	±2	±0,6	+0,3/+2,0	+0,3/+3,0
63	d11	d11	±0,8	±2	±0,7	+0,3/+2,0	+0,3/+3,0
80	d11	d11	±0,8	±3	±0,7	+0,3/+2,0	+0,3/+3,0
100	d11	d11	±1,0	±3	±0,7	+0,3/+2,0	+0,3/+3,0
125	d11	d11	±1,0	±3	±1,1	+0,3/+2,0	+0,3/+3,0

Installation on P1D with lock unit
If rotary control is to be retrofitted to a P1D with lock unit, the piston rod must be extended to provide the same WH dimensions as for the P1D base cylinder, as shown in the table below.

Cyl. dim mm	Piston rod extension on P1D with lock unit mm
32	11
40	14
50	20
63	20
80	26
100	31

P1D with rod guidance modules

The P1D series cylinders can be equipped with an external guiding device to prevent the piston rod from turning. The factory fitted guide gives a guided piston movement and enables the cylinder to take up turning moments on the piston rod, as well as greater transverse forces. The rod guidance is available with plain bearings or linear ball bearings and with H or U style. The bracket, which has pre-drilled mounting holes, is connected to the piston rod by means of a flexofitting, which prevents the build-up of stresses in the cylinder. P1D cylinders with guiding device are available with bores from 32 to 100 mm, and standard stroke lengths from 25 to 250 mm. Special stroke lengths up to 500 mm can also be obtained. Factory-fitting of the guiding device can be specified according to the order key on page 26. Separate guiding device kits can be supplied on request according to the order key below.

Technical data

Load See diagram on page 36
 Working medium Dry, filtered compressed air
 Working temperature -20 °C to +80 °C

Material specifications, guidance modules

Body Anodised aluminium
 Guide bars, H style Stainless steel for ball bearing
 chrome plated for plain bearing
 Front plate Anodised aluminium
 Guide bars, U style Stainless steel
 Front plate Zinc-plated steel
 Bearings Plain bearings
 Linear ball bearings

Other data as standard cylinder.

Order specifications for complete unit, please refer to pages 26 and 72

Order key for separate guidance module

P1E - 4KRH - 0100

Cylinder version	Bore size mm	Guide module type	Stroke length (mm)
E ISO 6431/VDMA cylinders	K 32	H H style, ball bearings	Same as for the cylinder e.g. 0100 = 100 mm.
	L 40	J H style, plain bearings	
	M 50	K U style, plain bearings	
	N 63		
	P 80		
	Q 100		

Technical information 'H style'

Rod guide with ball bearings

Maximum load carried

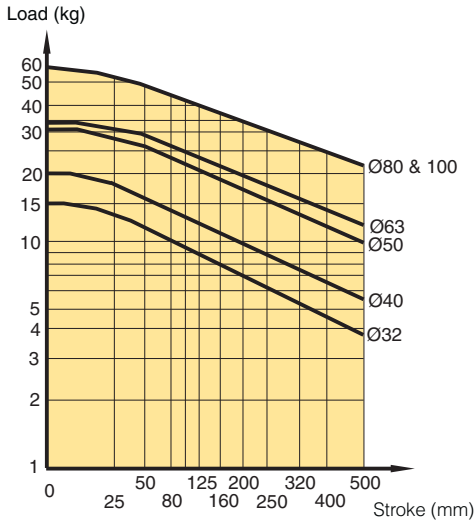

Rod guide with plain bearings

Maximum load carried

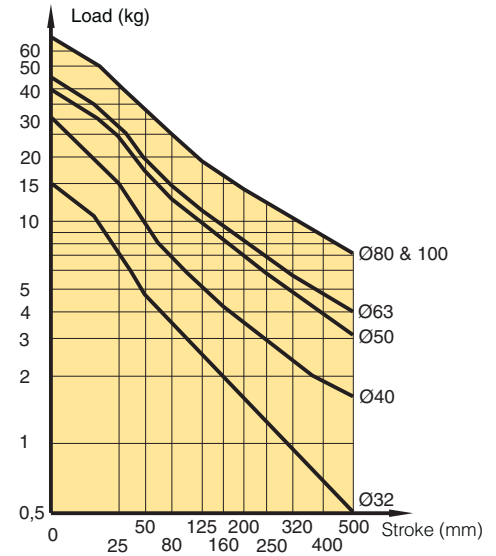

Maximum deflection/max load

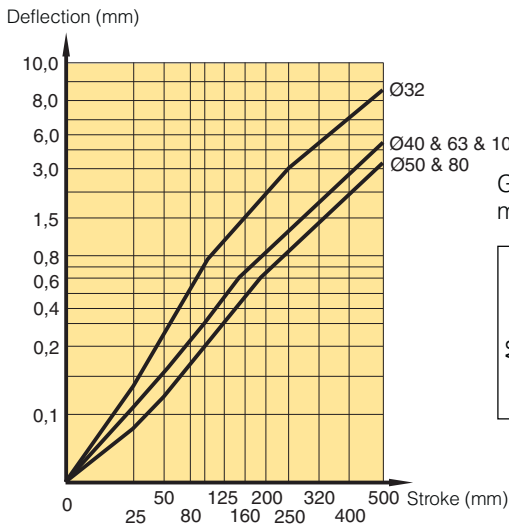

Maximum deflection/max load

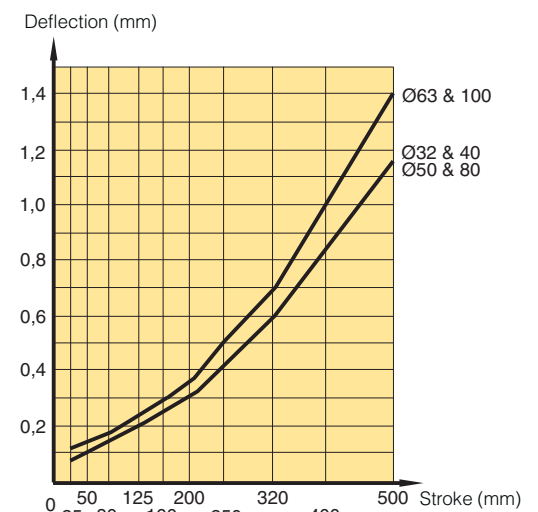

Maximum permissible torque (Nm)

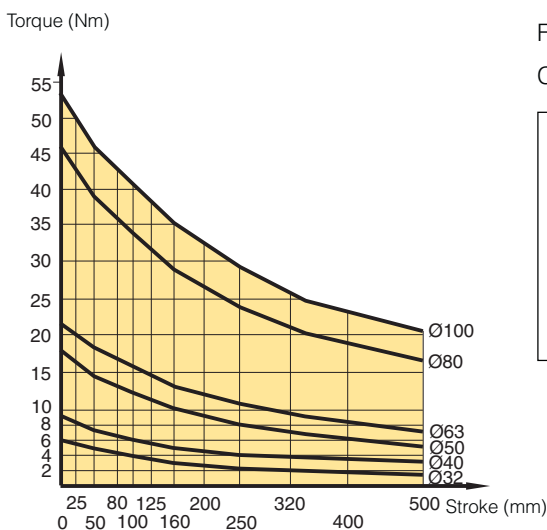

Formula:

$$C(Nm) = F(N) \times L(m)$$

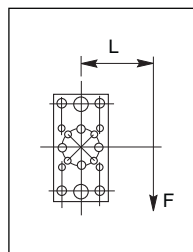

Maximum permissible torque (Nm)

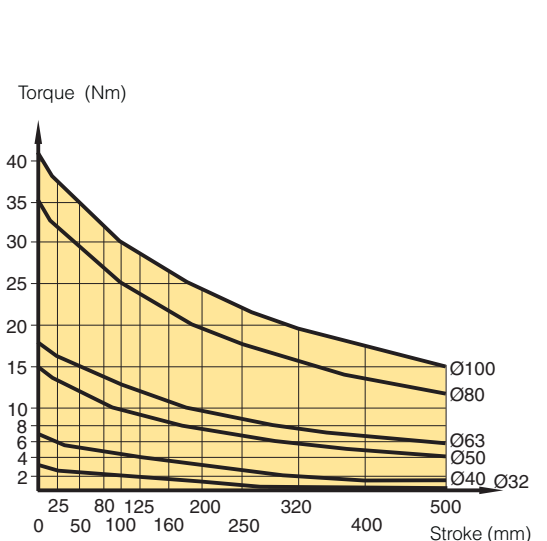

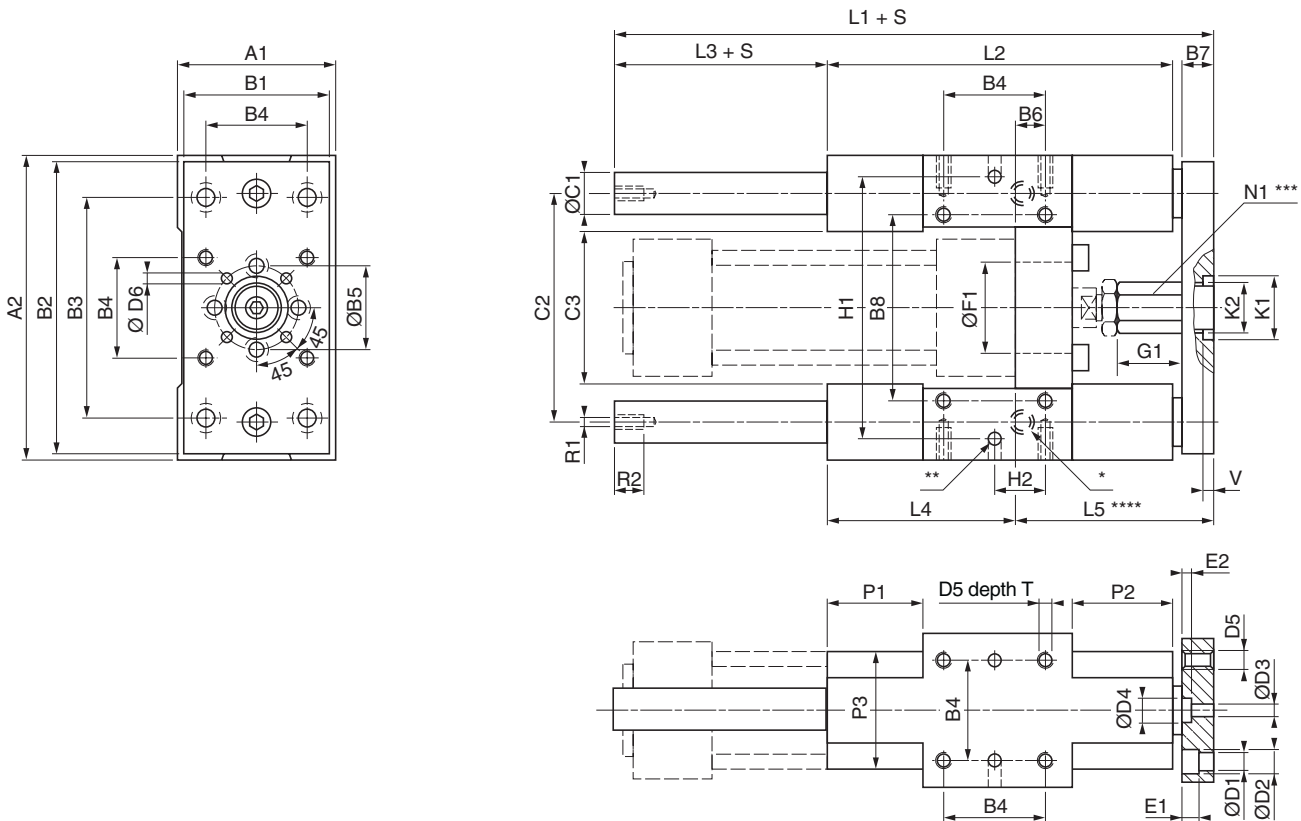

Dimensions, H style guidance modules

Cyl. bore mm	A ₁ mm	A ₂ mm	B ₁ mm	B ₂ mm	B ₃ mm	B ₄ mm	ØB ₅ mm	B ₆ mm	B ₇ mm	B ₈ mm	ØC ₁ mm	C ₂ mm	C ₃ mm	ØD ₁ mm	ØD ₂ mm	ØD ₃ mm
32	50	97	45	90	78	32,5	31,5	4,0	12	61	12	73,5	50	6,6	11	5,2
40	58	115	54	110	84	38,0	31,5	11,0	12	69	16	86,5	58	6,6	11	5,2
50	70	137	63	130	100	46,5	50,0	19,0	15	85	20	103,5	70	9,0	14	6,4
63	85	152	80	145	105	56,5	50,0	15,0	15	100	20	118,5	85	9,0	14	6,4
80	105	189	100	180	130	72,0	76,0	21,0	20	130	25	147,0	105	11,0	17	8,4
100	130	213	120	200	150	89,0	76,0	24,5	20	150	25	171,5	130	11,0	17	8,4

Cyl. bore mm	ØD ₄ mm	D ₅ mm	ØD ₆ mm	E ₁ mm	E ₂ mm	ØF ₁ ^{+0,1/0} mm	G ₁ mm	L ₁ mm	L ₂ mm	L ₃ mm	L ₄ mm	L ₅ mm	N ₁ mm	P ₁ ^{±1} mm	P ₂ ^{±1} mm
32	9	M6	4	7	4	30	17	150	120	15	71	64	17	36	31
40	9	M6	4	7	4	35	24	170	130	25	71	74	17	36	36
50	11	M8	4	9	9	40	27	192	150	24	79	89	24	42	44
63	11	M8	4	9	9	45	27	222	180	24	109	89	24	58	44
80	14	M10	6	11	5	45	32	247	200	24	113	110	30	50	52
100	14	M10	6	11	5	55	32	267	220	24	128	115	30	49	51

Cyl. bore mm	P ₃ mm	R ₁ mm	R ₂ mm	W mm	H ₁ ^{±0,05} mm	H ₂ mm	K ₁ ^{H8} mm	K ₂ mm	T mm	V ^{+0,3/0} mm
32	40	M6	11	5	81	16	24	19	12	4
40	44	M6	11	6	99	19	24	19	12	4
50	50	M8	16	8	119	23	38	26	16	4
63	60	M8	16	8	132	28	38	26	16	4
80	70	M10	16	10	166	36	46	32	20	4
100	70	M10	16	10	190	45	46	32	20	4

S = Stroke length

* Lubricators

** 6 hole Ø6^{H7}, depth 10^{+1/0}

*** Hexagon profile

**** Min adjustment=0, max.=W

Cylinder mountings

Type	Description	Cyl. bore Ø mm	Weight kg	Order code
Flange MF1/MF2	Intended for fixed mounting of cylinder. Flange can be fitted to front or rear end cover of cylinder. Materials Flange: Surface-treated steel, black Mounting screws acc. to DIN 6912: Zinc-plated steel 8.8 Supplied complete with mounting screws for attachment to cylinder.	32	0,23	P1C-4KMB P1C-4LMB P1C-4MMB P1C-4NMB P1C-4PMB P1C-4QMB P1C-4RMB
		40	0,28	
		50	0,53	
		63	0,71	
		80	1,59	
		100	2,19	
125	3,78			



According to ISO MF1/MF2, VDMA 24 562, AFNOR

Cyl. bore mm	d1 mm	FB mm	TG1 mm	E mm	R mm	MF mm	TF mm	UF mm	I1 mm	W* mm	ZF* mm	ZB* mm
	H11	H13			JS14	JS14	JS14		-0,5			
32	30	7	32,5	45	32	10	64	80	5,0	16	130	123,5
40	35	9	38,0	52	36	10	72	90	5,0	20	145	138,5
50	40	9	46,5	65	45	12	90	110	6,5	25	155	146,5
63	45	9	56,5	75	50	12	100	120	6,5	25	170	161,5
80	45	12	72,0	95	63	16	126	150	8,0	30	190	177,5
100	55	14	89,0	115	75	16	150	170	8,0	35	205	192,5
125	60	16	110,0	140	90	20	180	205	10,5	45	245	230,5

S = Stroke length * Does not apply to cylinders with lock unit, please refer to page 44

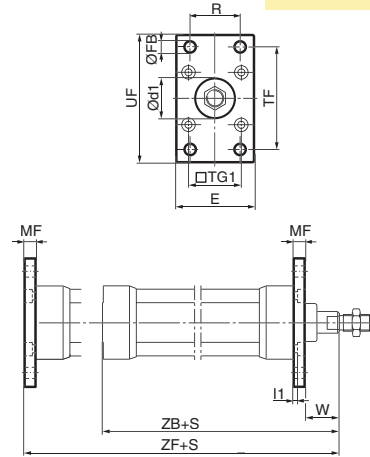

Foot bracket MS1



Intended for fixed mounting of cylinder. Foot bracket can be fitted to front and rear end covers of cylinder.

Materials
Foot bracket: Surface-treated steel, black
Mounting screws acc. to DIN 912: Zinc-plated steel 8.8

Supplied in pairs with mounting screws for attachment to cylinder.

32	0,06**
40	0,08**
50	0,16**
63	0,25**
80	0,50**
100	0,85**
125	1,48**

** Weight per item

P1C-4KMF
P1C-4LMF
P1C-4MMF
P1C-4NMF
P1C-4PMF
P1C-4QMF
P1C-4RMF

According to ISO MS1, VDMA 24 562, AFNOR

Cyl. bore mm	AB mm	TG1 mm	E mm	TR mm	AO mm	AU mm	AH mm	I7 mm	AT mm	I9 mm	SA* mm
	H14			JS14			JS15			JS14	
32	7	32,5	45	32	10	24	32	30	4,5	17,0	142
40	9	38,0	52	36	8	28	36	30	4,5	18,5	161
50	9	46,5	65	45	13	32	45	36	5,5	25,0	170
63	9	56,5	75	50	13	32	50	35	5,5	27,5	185
80	12	72,0	95	63	14	41	63	49	6,5	40,5	210
100	14	89,0	115	75	15	41	71	54	6,5	43,5	220
125	16	110,0	140	90	22	45	90	71	8,0	60,0	250

S = Stroke length * Does not apply to cylinders with lock unit, please refer to page 44

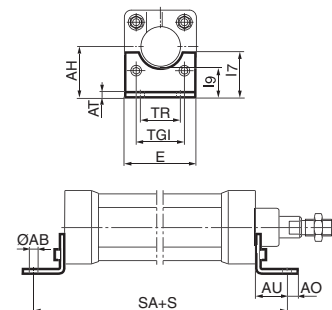

Pivot bracket with rigid bearing



Intended for flexible mounting of cylinder. The pivot bracket can be combined with clevis bracket MP2.

Materials
Pivot bracket: Surface-treated aluminium, black
Bearing: Sintered oil-bronze bushing

32	0,06
40	0,08
50	0,15
63	0,20
80	0,33
100	0,49
125	1,02

P1C-4KMD
P1C-4LMD
P1C-4MMD
P1C-4NMD
P1C-4PMD
P1C-4QMD
P1C-4RMD

According to CETOP RP 107 P, VDMA 24 562, AFNOR

Cyl. bore mm	CK mm	S5 mm	K1 mm	K2 mm	G1 mm	G2 mm	EM mm	G3 mm	CA mm	H6 mm	R1 mm
	H9	H13	JS14		JS14	JS14			JS15		
32	10	6,6	38	51	21	18	25,5	31	32	8	10,0
40	12	6,6	41	54	24	22	27,0	35	36	10	11,0
50	12	9,0	50	65	33	30	31,0	45	45	12	13,0
63	16	9,0	52	67	37	35	39,0	50	50	12	15,0
80	16	11,0	66	86	47	40	49,0	60	63	14	15,0
100	20	11,0	76	96	55	50	59,0	70	71	15	19,0
125	25	14,0	94	124	70	60	69,0	90	90	20	22,5

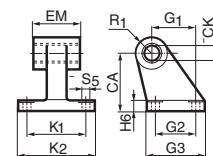

Cylinder mountings

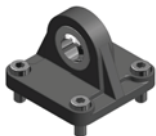
Type	Description	Cyl. bore Ø mm	Weight kg	Order code
Swivel eye bracket 	Intended for use together with clevis bracket GA	32	0,08	P1C-4KMSA P1C-4LMSA P1C-4MMSA P1C-4NMSA P1C-4PMSA P1C-4QMSA P1C-4RMSA
	Material	40	0,11	
	Bracket: Surface-treated aluminium, black	50	0,20	
	Swivel bearing acc. to DIN 648K: Hardened steel	63	0,27	
		80	0,52	
		100	0,72	
	Supplied complete with mounting screws for attachment to cylinder.	125	1,53	

According to VDMA 24 562, AFNOR

Cyl. bore mm	E	B1	B2	EN	R1	R2	FL	I2	L	CN	XD*	Z
mm	mm	mm	mm	mm	mm	mm	mm	mm	mm	mm	mm	mm
32	45	10,5	-	14	16	-	22	5,5	12	10	142	4°
40	52	12,0	-	16	18	-	25	5,5	15	12	160	4°
50	65	15,0	51	21	21	19	27	6,5	15	16	170	4°
63	75	15,0	-	21	23	-	32	6,5	20	16	190	4°
80	95	18,0	-	25	29	-	36	10,0	20	20	210	4°
100	115	18,0	-	25	31	-	41	10,0	25	20	230	4°
125	140	25,0	-	37	40	-	50	10,0	30	30	275	4°

S = Stroke length * Does not apply to cylinders with lock unit, please refer to page 44

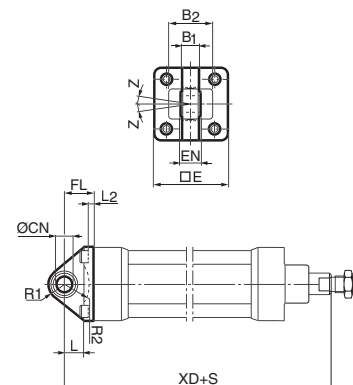

Clevis bracket MP2



Intended for flexible mounting of cylinder. Clevis bracket MP2 can be combined with clevis bracket MP4.

Materials
 Clevis bracket: Surface-treated aluminium, black
 Pin: Surface hardened steel
 Circlips according to DIN 471: Spring steel
 Mounting screws acc. to DIN 912: Zinc-plated steel 8.8

Supplied complete with mounting screws for attachment to cylinder.

32	0,08	P1C-4KMT P1C-4LMT P1C-4MMT P1C-4NMT P1C-4PMT P1C-4QMT P1C-4RMT
40	0,11	
50	0,14	
63	0,29	
80	0,36	
100	0,64	
125	1,17	

According to ISO MP2, VDMA 24 562, AFNOR

Cyl. bore mm	C	E	UB	CB	FL	L	I2	CD	MR	XD*
mm	mm	mm	h14 mm	H14 mm	±0,2 mm	mm	mm	H9 mm	mm	mm
32	53	45	45	26	22	13	5,5	10	10	142
40	60	52	52	28	25	16	5,5	12	12	160
50	68	65	60	32	27	16	6,5	12	12	170
63	78	75	70	40	32	21	6,5	16	16	190
80	98	95	90	50	36	22	10,0	16	16	210
100	118	115	110	60	41	27	10,0	20	20	230
125	139	140	130	70	50	30	10,0	25	25	275

S = Stroke length * Does not apply to cylinders with lock unit, please refer to page 44

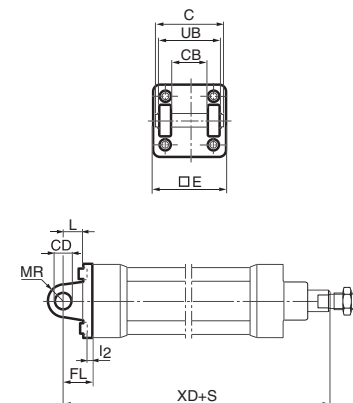

Cylinder mountings

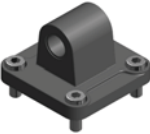
Type	Description	Cyl. bore Ø mm	Weight kg	Order code
Clevis bracket MP4 	Intended for flexible mounting of cylinder. Clevis bracket MP4 can be combined with clevis bracket MP2. Materials Clevis bracket: Surface-treated aluminium, black Mounting screws acc. to DIN 912: Zinc-plated steel 8.8 Supplied complete with mounting screws for attachment to cylinder.	32	0,09	P1C-4KME P1C-4LME P1C-4MME P1C-4NME P1C-4PME P1C-4QME P1C-4RME
		40	0,13	
		50	0,17	
		63	0,36	
		80	0,46	
		100	0,83	
125	1,53			

According to ISO MP4, VDMA 24 562, AFNOR

Cyl. bore mm	E mm	EW mm	FL mm	L ±0,2 mm	I2 mm	CD mm	MR H9 mm	XD* mm
32	45	26	22	13	5,5	10	10	142
40	52	28	25	16	5,5	12	12	160
50	65	32	27	16	6,5	12	12	170
63	75	40	32	21	6,5	16	16	190
80	95	50	36	22	10,0	16	16	210
100	115	60	41	27	10,0	20	20	230
125	140	70	50	30	10,0	25	25	275

S = Stroke length * Does not apply to cylinders with lock unit, please refer to page 44

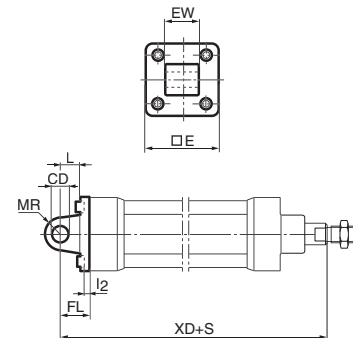

Clevis bracket GA

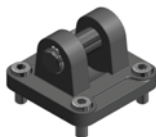

Intended for flexible mounting of cylinder. Clevis bracket GA can be combined with pivot bracket with swivel bearing, swivel eye bracket and swivel rod eye.

Materials
Clevis bracket: Surface-treated aluminium
Pin: Surface hardened steel
Locking pin: Spring steel
Circlips according to DIN 471: Spring steel
Mounting screws acc. to DIN 912: Zinc-plated steel 8.8

Supplied complete with mounting screws for attachment to cylinder.

32	0,09	P1C-4KMCA P1C-4LMCA P1C-4MMCA P1C-4NMCA P1C-4PMCA P1C-4QMCA P1C-4RMCA
40	0,13	
50	0,17	
63	0,36	
80	0,58	
100	0,89	
125	1,75	

According to VDMA 24 562, AFNOR

Cyl. bore mm	C mm	E mm	B2 d12 mm	B1 H14 mm	T mm	B3 mm	R2 mm	L1 mm	FL ±0,2 mm	I2 mm	L mm	CN F7 mm	R1 mm	XD* mm
32	41	45	34	14	3	3,3	17	11,5	22	5,5	12	10	11	142
40	48	52	40	16	4	4,3	20	12,0	25	5,5	15	12	13	160
50	54	65	45	21	4	4,3	22	14,0	27	6,5	17	16	18	170
63	60	75	51	21	4	4,3	25	14,0	32	6,5	20	16	18	190
80	75	95	65	25	4	4,3	30	16,0	36	10,0	20	20	22	210
100	85	115	75	25	4	4,3	32	16,0	41	10,0	25	20	22	230
125	110	140	97	37	6	6,3	42	24,0	50	10,0	30	30	30	275

S = Stroke length * Does not apply to cylinders with lock unit, please refer to page 44

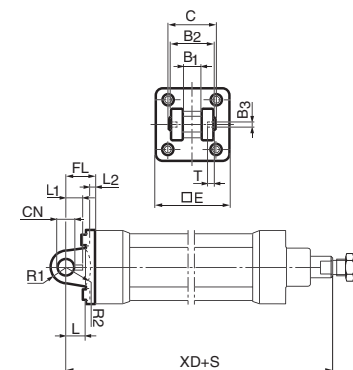

Stainless steel Pin Set GA

Materials
Pin: Stainless steel
Locking pin: Stainless steel
Circlips according to DIN 471: Stainless steel

32	0,05	9301054311 9301054312 9301054313 9301054314 9301054315 9301054316 9301054317
40	0,06	
50	0,07	
63	0,07	
80	0,17	
100	0,31	
125	0,54	

For mounting screws in stainless steel see page 61.

Cylinder mountings

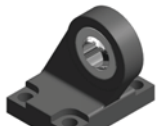
Type	Description	Cyl. bore Ø mm	Weight kg	Order code
Pivot bracket with swivel bearing 	Intended for use together with clevis bracket GA.	32	0,18	P1C-4KMA P1C-4LMA P1C-4MMA P1C-4NMA P1C-4PMA P1C-4QMA P1C-4RMA
	Material	40	0,25	
	Pivot bracket: Surface-treated steel, black	50	0,47	
	Swivel bearing acc. to DIN 648K: Hardened steel	63	0,57	
		80	1,05	
		100	1,42	
		125	3,10	

According to VDMA 24 562, AFNOR

Cyl. bore mm	CN H7 mm	S5 H13 mm	K1 JS14 mm	K2 mm	EU mm	G1 JS14 mm	G2 JS14 mm	EN mm	G3 mm	CH JS15 mm	H6 mm	ER mm	Z mm
32	10	6,6	38	51	10,5	21	18	14	31	32	10	16	4°
40	12	6,6	41	54	12,0	24	22	16	35	36	10	18	4°
50	16	9,0	50	65	15,0	33	30	21	45	45	12	21	4°
63	16	9,0	52	67	15,0	37	35	21	50	50	12	23	4°
80	20	11,0	66	86	18,0	47	40	25	60	63	14	28	4°
100	20	11,0	76	96	18,0	55	50	25	70	71	15	30	4°
125	30	14,0	94	124	25,0	70	60	37	90	90	20	40	4°

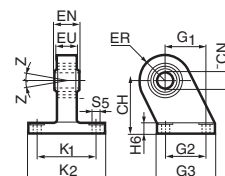

Mounting kit

	Mounting kit for back to back mounted cylinders, 3 and 4 position cylinders.	32	0,060	P1E-6KB0 P1E-6LB0 P1E-6MB0 P1E-6NB0 P1E-6PB0 P1E-6QB0
	Material:	40	0,078	
	Mounting: Aluminium	50	0,162	
	Mounting screws: Zinc-plated steel 8.8	63	0,194	
		80	0,450	
		100	0,672	
		100	0,672	

Cyl. bore mm	E mm	TG mm	ØFB mm	MF mm	A mm	ØBA mm
32	50	32,5	6,5	5	16	30
40	60	38,0	6,5	5	16	35
50	66	46,5	8,5	6	20	40
63	80	56,5	8,5	6	20	45
80	100	72,0	10,5	8	25	45
100	118	89,0	10,5	8	25	55

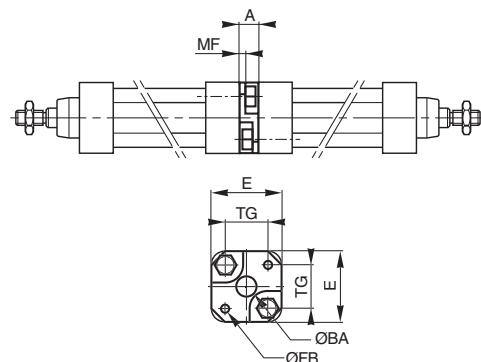

Pivot bracket for MT4

	Intended for use together with central trunnion MT4.	32	0,04*	9301054261 9301054262 9301054262 9301054264 9301054264 9301054266 9301054266
	Material	40	0,07*	
	Pivot bracket: Surface-treated aluminium	50	0,07*	
	Bearing acc. to DIN 1850 C: Sintered oil-bronze bushing	63	0,12*	
		80	0,12*	
		100	0,21*	
		125	0,21*	

* Weight per item.

According to ISO, VDMA 24 562, AFNOR

Cyl. bore mm	B1 mm	B2 mm	A mm	C mm	d1 mm	d2 H13 mm	H1 mm	H2 mm	fx45° min mm
32	46	18,0	32	10,5	12	6,6	30	15	1,0
40	55	21,0	36	12,0	16	9,0	36	18	1,6
50	55	21,0	36	12,0	16	9,0	36	18	1,6
63	65	23,0	42	13,0	20	11,0	40	20	1,6
80	65	23,0	42	13,0	20	11,0	40	20	1,6
100	75	28,5	50	16,0	25	14,0	50	25	2,0
125	75	28,5	50	16,0	25	14,0	50	25	2,0

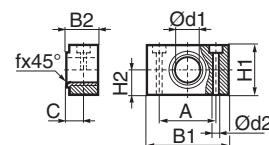

Cylinder mountings

Type	Description	Cyl. bore Ø mm	Weight kg	Order code
Centre trunnion MT4 for P1D-S	Intended for articulated mounting of cylinder. This mounting is available for the P1D Standard and for the tie-rod design of P1D. The trunnion is factory-fitted in the centre of the cylinder or at an optional location specified by the XV-measure – see the order code key. Combined with pivot bracket for MT4. Material: Trunnion: zinc plated steel	32	0,13	See order key on pages 27 and 72-74
		40	0,31	
		50	0,37	
		63	0,69	
		80	0,89	
		100	1,58	
Centre trunnion MT4 for P1D-T	Trunnion centred The central trunnion for the P1D-S and P1D-T is ordered with letter D in position 17 (no dimension specified in positions 18-20). See the order code key at pages 27. Trunnion with optional location The central trunnion for the P1D-S and P1D-T is ordered with letter G in position 17 and desired XV-measure (3-digit measure in mm) in positions 18-20. See the order code key at page 27. Trunnion loose P1D-S can also be ordered with the central trunnion loosely fitted to the cylinder (not fixed in position). This allows the position to be established at the time of installation. Ordered with letter G in position 17 and 000 in positions 18-20. Please refer to the order code key on page 27.	100	1,58	
		125	2,60	

Centre trunnion MT4 for P1D-T

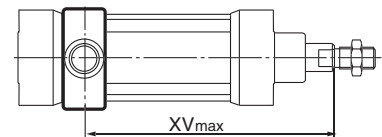
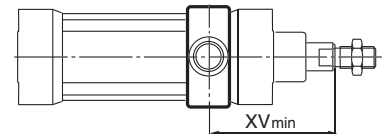
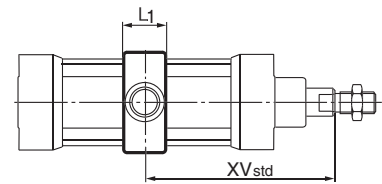
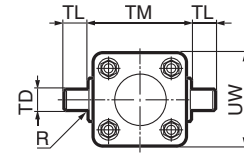
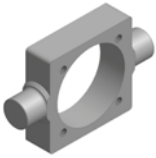

According to ISO MT4, VDMA 24 562, AFNOR

Cyl. bore mm	TM h14 mm	TL h14 mm	TD e9 mm	R mm	UW		L1		X1*	XV* _{min}		X2*	
					P1D-S	P1D-T	P1D-S	P1D-T		P1D-S	P1D-T	P1D-S	P1D-T
32	50	12	12	1,0	52	46	18	15	73,0	89	62	57	84
40	63	16	16	1,6	59	59	20	20	82,5	95	73	70	92
50	75	16	16	1,6	71	69	20	20	90,0	113	81	67	99
63	90	20	20	1,6	84	84	26	25	97,5	118	90	78	106
80	110	20	20	1,6	105	102	26	25	110,0	132	98	88	122
100	132	25	25	2,0	129	125	32	30	120,0	140	111	100	129
125	160	25	25	2,0	159	155	33	32	145,0	168	132	122	158

XVstd = X1 + Stroke length/2, XVmax = X2 + Stroke length

* Does not apply to cylinders with lock unit, please refer to page 44

Flange mounted trunnion

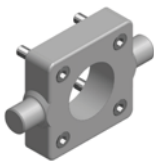

Intended for articulated mounting of cylinder. This trunnion can be flange mounted on the front or rear end cover of all P1D cylinders. At your choice, you can order a complete cylinder with factory-fitted flange mounted trunnion – see the order code key at pages 27 and 69.
Individual trunnions have order code as shown to the right.

Material:
Trunnion: zinc plated steel
Screws: zinc plated steel, 8.8

Delivered complete with mounting screws for attachment to the cylinder

According to ISO MT4, VDMA 24 562, AFNOR

Cyl. bore mm	TM h14 mm	TL h14 mm	TD e9 mm	R mm	UW mm	L1 mm	XV ₁ *	X*	Y mm
40	63	16	16	1,6	59	19	21,0	144,0	14
50	75	16	16	1,6	69	19	28,0	152,0	20
63	90	20	20	1,6	84	24	25,5	169,5	20
80	110	20	20	1,6	102	24	34,5	185,5	26
100	132	25	25	2,0	125	29	37,0	203,0	31

XV₂ = X + Stroke length * Does not apply to cylinders with lock unit, please refer to page 44

To fit a flange mounted trunnion at the front end cover of a P1D cylinder with lock unit, the piston rod must be extended. This is in order to provide the same WH dimensions as for the P1D base cylinder with dimension Y.

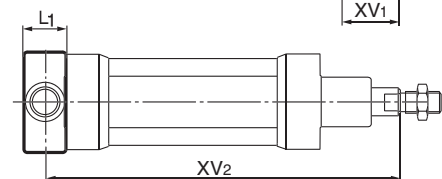
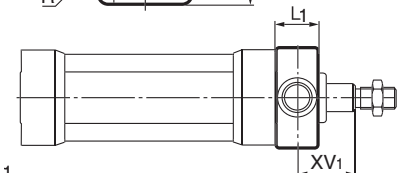
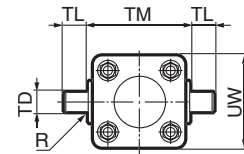

P1D-4KMYF
P1D-4LMYF
P1D-4MMYF
P1D-4NMYF
P1D-4PMYF
P1D-4QMYF

Piston rod mountings

Type	Description	Cyl. bore Ø mm	Weight kg	Order code
Swivel rod eye 	Swivel rod eye for articulated mounting of cylinder. Swivel rod eye can be combined with clevis bracket GA. Maintenance-free. Materials Swivel rod eye: Zinc-plated steel Swivel bearing according to DIN 648K: Hardened steel	32	0,08	P1C-4KRS P1C-4LRS P1C-4MRS P1C-4MRS P1C-4PRS P1C-4PRS P1C-4RRS
		40	0,12	
		50	0,25	
		63	0,25	
		80	0,46	
		100	0,46	
125	1,28			

Stainless steel swivel rod eye 	Stainless-steel swivel rod eye for articulated mounting of cylinder. Swivel rod eye can be combined with clevis bracket GA. Maintenance-free. Materials Swivel rod eye: Stainless steel Swivel bearing according to DIN 648K: Stainless steel	32	0,08	P1S-4JRT P1S-4LRT P1S-4MRT P1S-4MRT P1S-4PRT P1S-4PRT P1S-4RRT
		40	0,12	
		50	0,25	
		63	0,25	
		80	0,46	
		100	0,46	
125	1,28			

Use stainless steel nut (see page 58) with stainless steel swivel rod eye.

According to ISO 8139

Cyl. bore mm	A mm	B min mm	B max mm	CE mm	CN H9 mm	EN h12 mm	ER mm	KK	LE min mm	N mm	O mm	Z
32	20	48,0	55	43	10	14	14	M10x1,25	15	17	10,5	12°
40	22	56,0	62	50	12	16	16	M12x1,25	17	19	12,0	12°
50	28	72,0	80	64	16	21	21	M16x1,5	22	22	15,0	15°
63	28	72,0	80	64	16	21	21	M16x1,5	22	22	15,0	15°
80	33	87,0	97	77	20	25	25	M20x1,5	26	32	18,0	15°
100	33	87,0	97	77	20	25	25	M20x1,5	26	32	18,0	15°
125	51	123,5	137	110	30	37	35	M27x2	36	41	25,0	15°

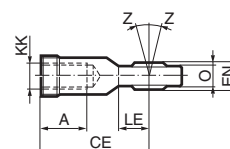
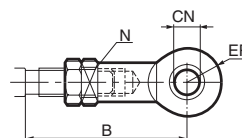

Clevis 	Clevis for articulated mounting of cylinder. Material Clevis, clip: Galvanized steel Pin: Hardened steel	32	0,09	P1C-4KRC P1C-4LRC P1C-4MRC P1C-4MRC P1C-4PRC P1C-4PRC P1C-4RRC
		40	0,15	
		50	0,35	
		63	0,35	
		80	0,75	
		100	0,75	
125	2,10			

Stainless steel clevis 	Stainless-steel clevis for articulated mounting of cylinder. Material Clevis: Stainless steel Pin: Stainless steel Circlips according to DIN 471: Stainless steel	32	0,09	P1S-4JRD P1S-4LRD P1S-4MRD P1S-4MRD P1S-4PRD P1S-4PRD P1S-4RRD
		40	0,15	
		50	0,35	
		63	0,35	
		80	0,75	
		100	0,75	
125	2,10			

Use stainless steel nut (see page 58) with stainless steel swivel rod eye.

According to ISO 8140

Cyl. bore mm	A mm	B min mm	B max mm	CE mm	CK h11/E9 mm	CL mm	CM mm	ER mm	KK	LE mm	O mm
32	20	45,0	52	40	10	20	10	16	M10x1,25	20	28,0
40	24	54,0	60	48	12	24	12	19	M12x1,25	24	32,0
50	32	72,0	80	64	16	32	16	25	M16x1,5	32	41,5
63	32	72,0	80	64	16	32	16	25	M16x1,5	32	41,5
80	40	90,0	100	80	20	40	20	32	M20x1,5	40	50,0
100	40	90,0	100	80	20	40	20	32	M20x1,5	40	50,0
125	56	123,5	137	110	30	55	30	45	M27x2	54	72,0

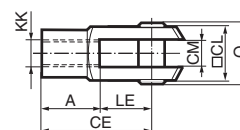
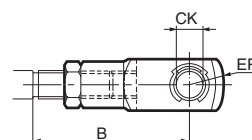

Piston rod mountings

Type	Description	Cyl. bore Ø mm	Weight kg	Order code
Flexo coupling	Flexo coupling for articulated mounting of piston rod. Flexo fitting is intended to take up axial angle errors within a range of ±4°. Material Flexo coupling, nut: Zinc-plated steel Socket: Hardened steel	32	0,21	P1C-4KRF P1C-4LRF P1C-4MRF P1C-4MRF P1C-4PRF P1C-4PRF P1C-4RRF
		40	0,22	
		50	0,67	
		63	0,67	
		80	0,72	
		100	0,72	
		125	1,80	

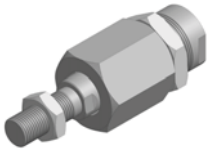

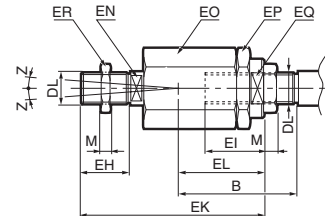

Supplied complete with galvanized adjustment nut.

Cyl. bore mm	B min mm	B max mm	DL	EH	EI	EK	EL	EN	EO	EP	EQ	ER	M	Z
32	36,0	43	M10x1,25	20	23	70	31	12	30	30	19	30	5,0	4°
40	37,0	43	M12x1,25	23	23	67	31	12	30	30	19	30	6,0	4°
50	53,0	61	M16x1,5	40	32	112	45	19	41	41	30	41	8,0	4°
63	53,0	61	M16x1,5	40	32	112	45	19	41	41	30	41	8,0	4°
80	57,0	67	M20x1,5	39	42	122	56	19	41	41	30	41	10,0	4°
100	57,0	67	M20x1,5	39	42	122	56	19	41	41	30	41	10,0	4°
125	75,5	89	M27x2	48	48	145	60	24	55	55	32	55	13,5	4°



Nut	Description	Cyl. bore mm	Weight kg	Order code
	Intended for fixed mounting of accessories to the piston rod. Material: Zinc-plated steel All P1D cylinders are delivered with a zinc-plated steel piston rod nut, except P1D Clean, which is delivered with a stainless steel piston rod nut instead.	32	0,007	9128985601 0261109910 9128985603 9128985603 0261109911 0261109911 0261109912
		40	0,010	
		50	0,021	
		63	0,021	
		80	0,040	
		100	0,040	
		125	0,100	

Stainless steel nut	Description	Cyl. bore mm	Weight kg	Order code
	Intended for fixed mounting of accessories to the piston rod. Material: Stainless steel A2 All P1D cylinders are delivered with a zinc-plated steel piston rod nut, except P1D Clean, which is delivered with a stainless steel piston rod nut instead.	32	0,007	9126725404 9126725405 9126725406 9126725406 0261109921 0261109921 0261109922
		40	0,010	
		50	0,021	
		63	0,021	
		80	0,040	
		100	0,040	
		125	0,100	

Acid-proof nut	Description	Cyl. bore mm	Weight kg	Order code
	Intended for fixed mounting of accessories to the piston rod. Material: Acid-proof steel A4 Cylinders with acid-proof piston rod are supplied with nut of acid-proof steel	32	0,007	0261109919 0261109920 0261109917 0261109917 0261109916 0261109916 0261109918
		40	0,010	
		50	0,021	
		63	0,021	
		80	0,040	
		100	0,040	
		125	0,100	

According to DIN 439 B

Cyl. bore mm	A mm	B mm	C
32	17	5,0	M10x1,25
40	19	6,0	M12x1,25
50	24	8,0	M16x1,5
63	24	8,0	M16x1,5
80	30	10,0	M20x1,5
100	30	10,0	M20x1,5
125	41	13,5	M27x2

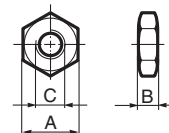

Combinations

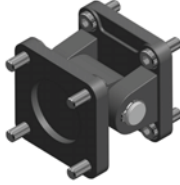
Type	Description	Cyl. bore Ø mm	Weight kg	Order code
Clevis bracket MP4 	Clevis bracket MP2 In this combination the clevis bracket MP4 is attached to the cylinder.	32	0,17	P1C-4KML
		40	0,24	P1C-4LML
		50	0,31	P1C-4MML
		63	0,65	P1C-4NML
		80	0,82	P1C-4PML
		100	1,47	P1C-4QML
		125	2,70	P1C-4RML
		32	0,13	P1C-4KMG
		40	0,23	P1C-4LMG
		50	0,35	P1C-4MMG
		63	0,61	P1C-4NMG
		80	0,66	P1C-4PMG
		100	1,53	P1C-4QMG
		125	2,83	P1C-4RMG

Delivered as individual mountings, not mounted together, and complete with mounting screws for attachment to cylinder.

Cyl. bore mm	A	B	C	CD	d3	E	FL	L	TG1	XA*	XD*	Z
	mm	mm	mm	mm	H9 H13	mm	±0,2	mm	mm	mm	mm	mm
32	9	44	53	10	6,6	45	22	13	32,5	164	142	112°
40	9	50	60	12	6,6	52	25	16	38,0	185	160	122°
50	11	54	68	12	9,0	65	27	16	46,5	197	170	94°
63	11	64	78	16	9,0	75	32	21	56,5	222	190	112°
80	14	72	98	16	11,0	95	36	22	72,0	246	210	82°
100	14	82	118	20	11,0	115	41	27	89,0	271	230	90°
125	20	100	139	25	13,5	140	50	30	110,0	325	275	94°

S = Stroke length * Does not apply to cylinders with lock unit, please refer to page 44

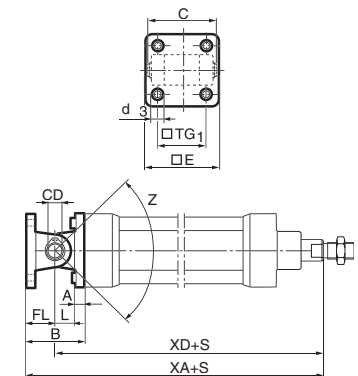

Clevis bracket MP2 	Pivot bracket with rigid bearing In this combination the clevis bracket MP2 is attached to the cylinder.	32	0,14	P1C-4KMP
		40	0,19	P1C-4LMP
		50	0,29	P1C-4MMP
		63	0,49	P1C-4NMP
		80	0,69	P1C-4PMP
		100	1,13	P1C-4QMP
		125	2,83	P1C-4RMP
		32	0,10	P1C-4KMK
		40	0,18	P1C-4LMK
		50	0,33	P1C-4MMK
		63	0,45	P1C-4NMK
		80	0,93	P1C-4PMK
		100	1,19	P1C-4QMK
		125	2,32	P1C-4RMK



Delivered as individual mountings, not mounted together, and complete with mounting screws for attachment to cylinder.

Cyl. bore mm	A	CA	D	E	G1	G2	G3	H6	k1	k2	S5	XA*	XD*	Z1	Z2
	mm	JS15	mm	mm	JS14	JS14	mm	mm	JS14	mm	H13	mm	mm	mm	mm
32	43	32	53	45	21	18	31	8	38	51	6,6	169,5	142	150°	18°
40	49	36	60	52	24	22	35	10	41	54	6,6	190,5	160	155°	18°
50	60	45	68	65	33	30	45	12	50	65	9,0	210,5	170	145°	18°
63	69	50	78	75	37	35	50	12	52	67	9,0	234,5	190	155°	20°
80	83	63	98	95	47	40	60	14	66	86	11,0	267,0	210	150°	20°
100	96	71	118	115	55	50	70	15	76	96	11,0	295,0	230	150°	15°
125	120	90	139	140	70	60	90	20	94	124	14,0	360,0	275	145°	18°

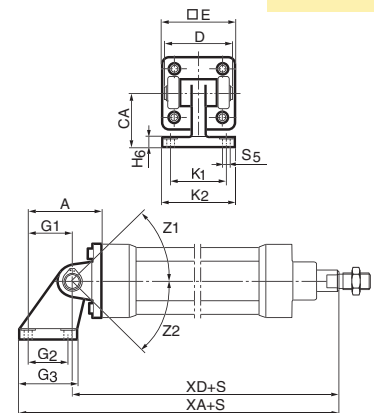
S = Stroke length * Does not apply to cylinders with lock unit, please refer to page 44

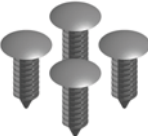

Accessories

Type	Description	Cyl. bore Ø mm	Weight kg	Order code
Stainless steel screw set MP2, MP4, MS1 and GA 	Set of stainless steel screws for fitting clevis brackets MP2, MP4 and GA onto the cylinder. The screws have an internal hexagonal head and are used in special environments, e.g. the food industry, or where there are extra demands for protection against corrosion. Material: According to DIN 912, Stainless steel, A2 4 pcs per pack.	32	0,02	9301054321
		40	0,02	9301054321
		50	0,05	9301054322
		63	0,05	9301054322
		80	0,09	9301054323
		100	0,09	9301054323
		125	0,15	9301054324
Stainless steel screw set for MF1/MF2 	Set of stainless steel screws for fitting flanges MF1/MF2 onto the cylinder. The screws have an internal hexagonal head and are used in special environments, e.g. the food industry, or where there are extra demands for protection against corrosion. Material: According to DIN 6912, Stainless steel, A2 4 pcs per pack	32	0,02	9301054331
		40	0,02	9301054331
		50	0,04	9301054332
		63	0,04	9301054332
		80	0,07	9301054333
		100	0,07	9301054333
		125	0,12	9301054334
Sealing plugs 	Set of sealing plugs to be fitted in unused end covers. The plugs can be used for all P1D cylinders to avoid collecting dirt and fluids in the end cover screw recesses. Material: Polyamid PA 4 pcs per pack	32	0,01	9121742201
		40	0,01	9121742201
		50	0,02	9121742202
		63	0,02	9121742202
		80	0,02	9121742203
		100	0,02	9121742203
		125	0,03	9121742204

Combinations

Type and description

Cylinders complete with mountings, sensors, speed regulation, fittings etc.

Order a complete working unit on a single order code instead of a lot of separate numbers. Save time in all phases, such as purchasing, goods reception and installation.

A factory installed complete cylinder makes your work more efficient!

Configure functions and equipment in the order key. See pages 24-25 and 70-74.



3 and 4 position cylinders

This type of cylinder function consists of two cylinders installed back to back. Two cylinders with the same stroke give a 3 position cylinder with a symmetrical centre position, whereas different strokes give a 4 position cylinder where the two central positions can be calculated from the different stroke lengths.

3 and 4 position cylinders can be ordered in two ways.

Factory-fitted P1D-T

Tie-rod P1D cylinders are completed at the factory and are joined together as one unit by special tie-rods, see position 9 in the order key. See pages 32 and 72-74.



Installation kit for all designs

There is an installation kit for cylinder bores 32 – 100 mm which makes it possible to join any two P1D cylinders together at any time, to make a 3 or 4 position cylinder.

Please refer to cylinder mountings, page 55.

Cylinder bore. mm	A, P1D-T mm	A, P1D-S mm
32	247	256
40	277	286
50	293	306
63	323	336
80	355	373
100	385	403
125	461	–

S=Stroke

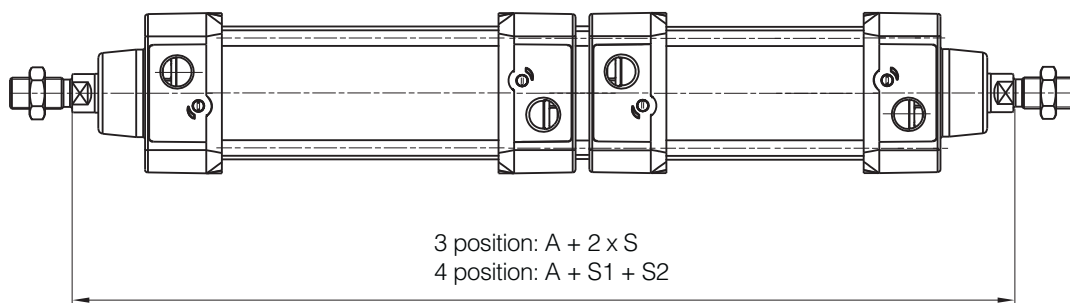

New drop-in sensors

The completely new "drop-in" P1D sensors can easily be installed from the side in the sensor groove, at any position along the piston stroke. The sensors are completely recessed and thus mechanically protected. Choose between electronic or reed sensors and several cable lengths and 8 mm and M12 connectors. The same standard sensors are used for all P1D versions, i.e. even for P1D Clean with the patent applied system of integrated sensors. Please note that the sensors with 8 mm and M12 connector should have cable lengths 1 m for P1D Clean to allow flexible positioning of the sensors, including longer stroke lengths. There is a double jointed adapter for the tie-rod version, which offers simple and flexible use of standard sensors.



Electronic sensors

The new electronic sensors are "Solid State", i.e. they have no moving parts at all. They are provided with short-circuit protection and transient protection as standard. The built-in electronics make the sensors suitable for applications with high on and off switching frequency, and where very long service life is required.

Technical data

Design	GMR (Giant Magnetic Resistance) magneto-resistive function
Installation	From side, down into the sensor groove, so-called drop-in
Outputs	PNP, normally open (also available in NPN design, normally closed, on request)
Voltage range	10-30 VDC 10-18 V DC, ATEX sensor
Ripple	max 10%
Voltage drop	max 2,5 V
Load current	max 100 mA
Internal consumption	max 10 mA
Actuating distance	min 9 mm
Hysteresis	max 1,5 mm
Repeatability accuracy	max 0,2 mm
On/off switching frequency	max 5 kHz
On switching time	max 2 ms
Off switching time	max 2 ms
Encapsulation	IP 67 (EN 60529)
Temperature range	-25 °C to +75 °C -20 °C to +45 °C, ATEX sensor
Indication	LED, yellow
Material housing	PA 12
Material screw	Stainless steel
Cable	PVC or PUR 3x0.25 mm ² see order code respectively

Reed sensors

The sensors are based on proven reed switches, which offer reliable function in many applications. Simple installation, a protected position on the cylinder and clear LED indication are important advantages of this range of sensors.

Technical data

Design	Reed element
Mounting	From side, down into the sensor groove, so-called drop-in
Output	Normally open , or normally closed
Voltage range	10-30 V AC/DC or 10-120 V AC/DC 24-230 V AC/DC
Load current	max 500 mA for 10-30 V or max 100 mA for 10-120 V max 30 mA for 24-230 V
Breaking power (resistive)	max 6 W/VA
Actuating distance	min 9 mm
Hysteresis	max 1,5 mm
Repeatability accuracy	0,2 mm
On/off switching frequency	max 400 Hz
On switching time	max 1,5 ms
Off switching time	max 0,5 ms
Encapsulation	IP 67 (EN 60529)
Temperature range	-25 °C to +75 °C
Indication	LED, yellow
Material housing	PA12
Material screw	Stainless steel
Cable	PVC or PUR 3x0.14 mm ² see order code respectively

Electronic sensors

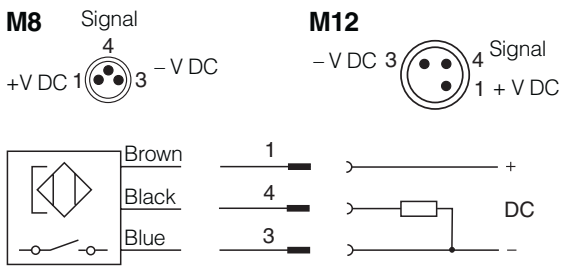

Reed sensors

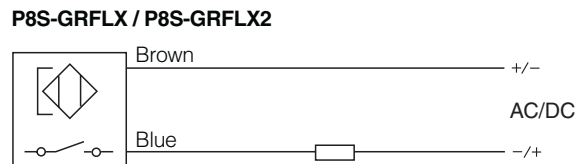
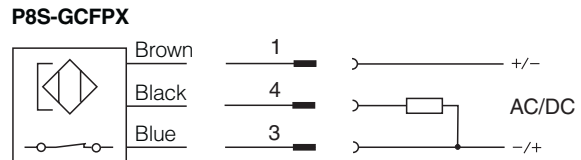
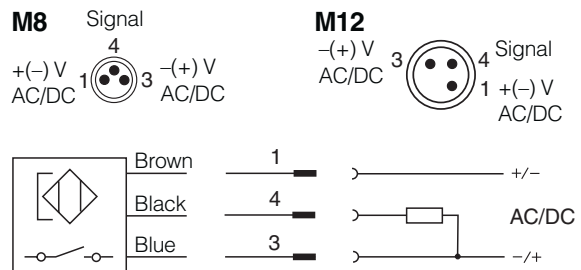

Dimensions

Sensors

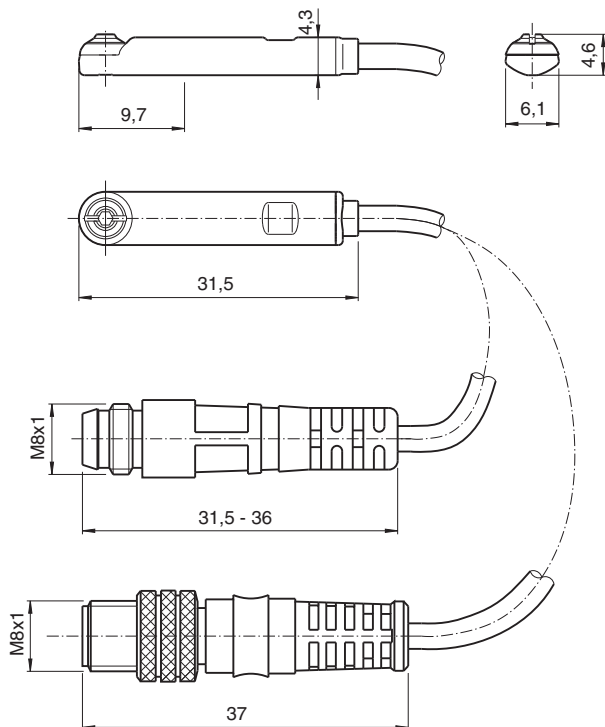

Adapter for P1D-T

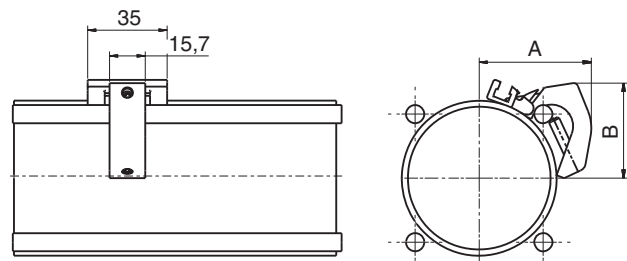

Cyl. bore mm	A mm	B mm
32	35	26
40	39	30
50	44	30
63	50	42
80	54	52
100	62	60
125	74	69

Ordering data

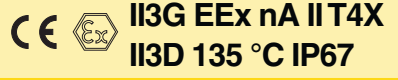
Output/function	Cable/connector	Weight kg	Order code
Electronic sensors , 10-30 V AC/DC			
PNP type, normally open	0,27 m PUR-cable and 8 mm snap-in male connector ¹⁾	0,007	P8S-GPSHX
PNP type, normally open	1,0 m PUR-cable and 8 mm snap-in male connector	0,013	P8S-GPSCX
PNP type, normally open	1,0 m PUR-cable and M8 screw male connector	0,013	P8S-GPCCX
PNP type, normally open	0,27 m PUR-cable and M12 screw male connector ¹⁾	0,015	P8S-GPMHX
PNP type, normally open	3 m PVC-cable without connector	0,030	P8S-GPFLX
PNP type, normally open	10 m PVC-cable without connector	0,110	P8S-GPFTX
Electronic sensor 18-30 V DC			
ATEX-certified			
		See ATEX information pages 18 - 21.	
Type PNP , normally open	3 m PVC-cable without connector	0,030	P8S-GPFLX/EX
Reed sensors , 10-30 V AC/DC			
Normally open	0,27 m PUR-cable and 8 mm snap-in male connector ¹⁾	0,007	P8S-GSSHX
Normally open	1,0 m PUR-cable and 8 mm snap-in male connector	0,013	P8S-GSSCX
Normally open	1,0 m PUR-cable and M8 male connector	0,013	P8S-GSCCX
Normally open	0,27 m PUR-cable and M12 screw male connector ¹⁾	0,015	P8S-GSMHX
Normally open	1,0 m PUR-cable and M12 screw male connector	0,023	P8S-GSMCX
Normally open	3 m PVC-cable without connector	0,030	P8S-GSFLX
Normally open	10 m PVC-cable without connector	0,110	P8S-GSFTX
Normally closed	5m PVC-cable without connector ²⁾	0,050	P8S-GCFPX
Reed sensors, 10-120 V AC/DC			
Normally open	3 m PVC-cable without connector	0,030	P8S-GRFLX
Reed sensorer, 24-230 V AC/DC			
Normalt öppen	3 m PVC-kabel utan kontakt ²⁾	0,030	P8S-GRFLX2

1) Not in combination with P1D Clean (too short cable)

2) Without LED

Adapter for tie-rod design

Description	Weight kg	Order code
Double jointed adapter for cylinder P1D-T cylinder bore Ø32 to Ø125 mm	0,07	P8S-TMA0X



Connecting cables with one connector

The cables have an integral snap-in female connector.



Type of cable	Cable/connector	Weight kg	Order code
Cables for sensors, complete with one female connector			
Cable, Flex PVC	3 m, 8 mm Snap-in connector	0,07	9126344341
Cable, Flex PVC	10 m, 8 mm Snap-in connector	0,21	9126344342
Cable, Super Flex PVC	3 m, 8 mm Snap-in connector	0,07	9126344343
Cable, Super Flex PVC	10 m, 8 mm Snap-in connector	0,21	9126344344
Cable, Polyurethane	3 m, 8 mm Snap-in connector	0,01	9126344345
Cable, Polyurethane	10 m, 8 mm Snap-in connector	0,20	9126344346
Cable, Polyurethane	5 m, M12 screw connector	0,07	9126344348
Cable, Polyurethane	10 m, M12 screw connector	0,20	9126344349

Cable connectors

Cable connectors for producing your own connecting cables. The connectors can be quickly attached to the cable without special tools. Only the outer sheath of the cable is removed. The connectors are available for M8 and M12 screw connectors and meet protection class IP 65.



Connector	Weight kg	Order code
M8 screw connector	0,017	P8CS0803J
M12 screw connector	0,022	P8CS1204J

Ready to use connecting cables with connectors at each end

As accessories the system comprises a large number of different cables in order to meet all requirements that may arise and to make the installation simple, fast and reliable. Cables with moulded 8 mm snap-in round contacts in both ends. The cables are available in two types, one with a straight male and female connectors respectively, and one with a straight 3-pole male connector in one end and an angled 3-pole female connector in the other end.



Technical data

Contacts

Moulded 8 mm snap-in male/female contacts.
Enclosure IP67

Cable

Conductor 3x0,25 mm² (32x0,10 mm²)
Sheath PVC/PUR
Colour Black

Cables with straight 3-pole male and female connectors respectively.

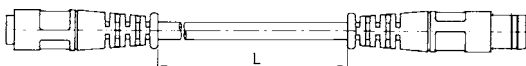

Cables with a straight 3-pole male connector in one end and an angled 3-pole female connector in the other end.

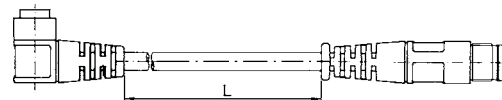

Designation	Weight kg	Order code
Cable with straight contacts, 0,2 m	0,02	9121717014
Cable with straight contacts, 0,3 m	0,02	9121717015
Cable with straight contacts, 0,5 m	0,03	9121717016
Cable with straight contacts, 1,0 m	0,03	9121717017
Cable with straight contacts, 2,0 m	0,05	9121717018
Cable with straight contacts, 3,0 m	0,07	9121717019
Cable with straight contacts, 5,0 m	0,12	9121717020
Cable with straight contacts, 10 m	0,23	9121717021

Designation	Weight kg	Order code
Cable with straight and angled connectors, 0,2 m	0,02	9121717022
Cable with straight and angled connectors, 0,3 m	0,02	9121717023
Cable with straight and angled connectors, 0,5 m	0,03	9121717024
Cable with straight and angled connectors, 1,0 m	0,03	9121717025
Cable with straight and angled connectors, 2,0 m	0,05	9121717026
Cable with straight and angled connectors, 3,0 m	0,07	9121717027
Cable with straight and angled connectors, 5,0 m	0,12	9121717028
Cable with straight and angled connectors, 10 m	0,23	9121717029

Connection block Valvetronic 110

The Valvetronic 110 is a connection block that can be used for collecting signals from sensors at various points on a machine and connecting them to the control system via a multicore cable. Valvetronic 110 can also be used for central connection of the multi-core cable to the outputs of a control system, and can be laid to a machine where the output signals can be connected. The connection block has ten 8 mm snap-in circular connectors and a multi-core cable which is available in lengths of 3 or 10 m. The connections on the block are numbered from 1 to 10. Blanking plugs are available for unused connections, as labels for marking the connections of each block.



Technical data

Connections:

Ten 3-pole numbered 8 mm round snap-in female contacts

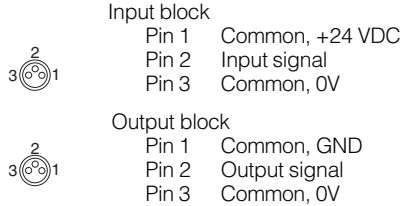

Electrical data:

Voltage: 24 VDC (max. 60 V AC/75 V DC) according to DIN 0110 class C
 Insulation group: max. 1 A per connection
 Load: total max. 3 A

Cable:

Length: 3 m or 10 m
 Type of cable: LifYY11Y
 Conductor: 12
 Area: 0.34 mm²
 Colour marking: According to DIN 47 100

Mechanical data

Enclosure: IP 67, DIN 40050 with fitted contacts and/or blanking plugs.
 Temperature: -20 °C to +70 °C





Material

Body: PA 6,6 VD according to UL 94
 Contact holder: PBTP
 Snap-in ring: LDPE
 Moulding mass: Epoxy
 Seal: NBR
 Screws: Plated steel

Industrial durability

Good chemical and oil resistance. Tests should be performed in aggressive environments.

Ordering data

Designation	Weight kg	Order code
 Connection block Valvetronic 110 with 3 m cable	0,32	9121719001
 Connection block Valvetronic 110 with 10 m cable	0,95	9121719002
 Blanking plugs (pack of 10) Use blanking plugs to close unused connections.	0,02	9121719003
 Labels (pack of 10) White labels to insert in grooves on the side of the connection	0,02	9121719004

Dimensions and wiring diagrams

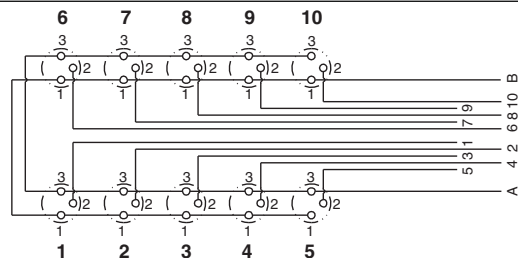
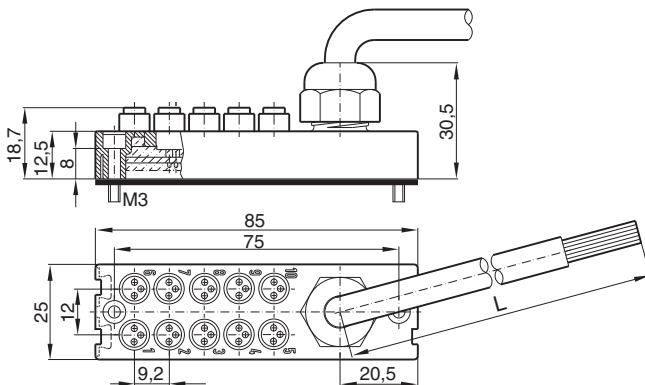

Conductor	Colour	Input	Output
1	Pink	Signal 1	Signal 1
2	Grey	Signal 2	Signal 2
3	Yellow	Signal 3	Signal 3
4	Green	Signal 4	Signal 4
5	White	Signal 5	Signal 5
6	Red	Signal 6	Signal 6
7	Black	Signal 7	Signal 7
8	Violet	Signal 8	Signal 8
9	Grey-Pink	Signal 9	Signal 9
10	Red-Blue	Signal 10	Signal 10
A	Blue	0 V	0 V
B	Brown	+24 V	PE

P1D Seal kits

Complete seal kits consisting of:

Piston seals

Cushioning seals

Piston rod bearing

Combined piston rod seal and scraper ring

O-rings

Material specification, see page 15



Order codes

Cyl.bore mm	P1D cylinder version			
	Standard P1D-S, P1D-T, P1D-C, P1D-F	High Temp P1D-S	Low Temp P1D-S	Hydraulic P1D-S
32	P1D-6KRN	P1D-6KRF	P1D-6KRL	P1D-6KRH
40	P1D-6LRN	P1D-6LRF	P1D-6LRL	P1D-6LRH
50	P1D-6MRN	P1D-6MRF	P1D-6MRL	P1D-6MRH
63	P1D-6NRN	P1D-6NRF	P1D-6NRL	P1D-6NRH
80	P1D-6PRN	P1D-6PRF	P1D-6PRL	P1D-6PRH
100	P1D-6QRN	P1D-6QRF	P1D-6QRL	P1D-6QRH
125	P1D-6RRN	P1D-6RRF	P1D-6RRL	P1D-6RRH

Cyl.bore mm	P1D optional cylinder versions
	Through rod Standard temperature P1D-S, P1D-T, P1D-C, P1D-F
32	P1D-6KRNF
40	P1D-6LRNF
50	P1D-6MRNF
63	P1D-6NRNF
80	P1D-6PRNF
100	P1D-6QRNF
125	P1D-6RRNF

Grease for P1D

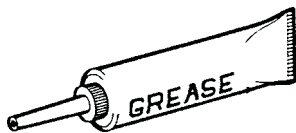

Standard	30g	9127394541
High temperature	30g	9127394521
Low temperature	30g	9127394541

There is a P1D cylinder for every application

P1D Standard

The basic platform in the P1D family offers high performance, thanks to its very durable and user-friendly design. The order codes for all common cylinder versions follow the same principles as our previous cylinder ranges, P1C and P1E. This makes it easy to identify and order the corresponding P1D cylinder.

1	2	3	4	5	6	7	8	9	10	11	12	13	14	15
P	1	D	-	S	0	3	2	M	S	-	0	1	0	0



P1D Clean with integrated sensors

The obvious choice for stringent hygiene requirements, specially designed for demanding applications. The perfect fit for the food processing industry. Built-in sensors are selected in position 18.

1	2	3	4	5	6	7	8	9	10	11	12	13	14	15	16	17	18	19	20
P	1	D	-	C	0	5	0	M	S	-	0	3	2	0	N	N	C	N	N



P1D Clean without sensor function

The clean cylinder for applications which do not require sensors. This is the only P1D Clean cylinder which is ordered with a 15-digit order code.

1	2	3	4	5	6	7	8	9	10	11	12	13	14	15
P	1	D	-	C	0	5	0	M	S	-	0	2	5	0



Flexible Porting

The P1D Flexible Porting cylinder is available with both connections in one end of the end covers. This cylinder always has a 20-digit order code, where the position of the cylinder ports is defined in position 11 and the type of fitting and tube dimension is chosen in position 20.

1	2	3	4	5	6	7	8	9	10	11	12	13	14	15	16	17	18	19	20
P	1	D	-	F	0	5	0	M	S	B	0	3	2	0	N	N	N	N	0



P1D Clean with Flexible Porting

Combine P1D Clean with having both connections in one end, by using the Flexible Porting option.

1 2 3 4 5 6 7 8 9 10 11 12 13 14 15 16 17 18 19 20
P1D-C050MSB0320NNCN8



P1D Tie-Rod

The same basic high technology design as all other P1D cylinder versions, but with a tie-rod design. Follows the same order code principles as our previous P1E range.

1 2 3 4 5 6 7 8 9 10 11 12 13 14 15
P1D-T050MS-0125



P1D cylinder with piston rod locking

The P1D cylinder is available in a version with piston rod locking, allowing the piston rod to be locked in any position. The lock unit, of the air/spring actuated type, is integrated in the front end piece of the cylinder.

P1D Standard with piston rod locking

1 2 3 4 5 6 7 8 9 10 11 12 13 14 15
P1D-L050MC-0250

P1D Clean with piston rod locking

1 2 3 4 5 6 7 8 9 10 11 12 13 14 15
P1D-D050MC-0250



P1D complete working unit

P1D Standard can be ordered with a factory-fitted valve and hosing. The valve series is the robust and compact Viking series, with product code P2L-A (for cylinder bores 32-63), P2L-B (for cylinder bores 80-100) and P2L-D (for cylinder bore 125).

1 2 3 4 5 6 7 8 9 10 11 12 13 14 15 16 17 18 19 20
P1D-V050MS10320NNNH



15-digit order code

1 2 3 4 5 6 7 8 9 10 11 12 13 14 15
P 1 D - S 0 4 0 M S - 0 3 2 0

5

Cylinder version	
S	Standard
C	Clean ²⁾
F	Flexible Porting
T	Tie-Rod
V	Standard with factory fitted valve
L	Standard with lock unit ¹⁹⁾
D	Clean with lock unit ¹⁹⁾
4	Standard with lock unit and factory fitted valve ¹⁹⁾

6-7-8

Cylinder bore mm
032
040
050
063
080
100
125

6

Rod extension only

Cylinder bore mm	
K	32
L	40
M	50
N	63
P	80
Q	100
R	125

7-8

Piston rod extension			
E.g. KR5 = Cylinder bore 32 mm with piston rod extension = 255 mm			
01-99	1-99	N0-N9	220-229
A0-A9	100-109	P0-P9	230-239
B0-B9	110-119	Q0-Q9	240-249
C0-C9	120-129	R0-R9	250-259
D0-D9	130-139	S0-S9	260-269
E0-E9	140-149	T0-T9	270-279
F0-F9	150-159	U0-U9	280-289
G0-G9	160-169	V0-V9	290-299
H0-H9	170-179	W0-W9	300-309
J0-J9	180-189	X0-X9	310-319
K0-K9	190-199	Y0-Y9	320-329
L0-L9	200-209	Z0-Z9	330-339
M0-M9	210-219		

CE II 2GD c T4 120 °C

Valid for P1D-S***MS-****, see ATEX information pages 18 - 21.

12-13-14-15

Stroke length see next page

10

Cylinder ports Flexible porting		Port location
Both front	Both rear	
H ³⁾ J ³⁾	G threads, BSPP (Ø 80-125)	
B ⁴⁾ C ⁴⁾	Push-in, metric (Ø 32-80)	
Cylinder ports Other		
— G threads, BSPP rear and front		
Factory fitted valve type		
0	air actuated	
1	Electrically actuated 24 V UC, LED+VDR (AC/DC Universal Current) Complete with rectifier	
4	Electrically actuated 24 V UC, LED+VDR med with 5 m integral cable (AC/DC Universal Current) Complete with rectifier	
7	Electrically actuated 24 V UC, LED+VDR med with 10 m integral cable (AC/DC Universal Current) Complete with rectifier	
2	115 V/50 Hz, 120 V/60 Hz, LED+VDR	
3	230 V/50 Hz, 240 V/60 Hz, LED+VDR	

Piston rod material		Seals	
Stainless steel	Chromium-plated steel	Acid-proof steel	Chrom.-pl. stainless steel
S	C	M	R
F	G	N	D
L	K	P	E
—	J	—	Z
Standard -20 °C to +80 °C.			
High temperature version ⁶⁾ -10 °C to +150 °C. No magnetic function			
Low temperature version ⁶⁾ -40 °C to +40 °C.			
Low pressure hydraulic ^{6) 24)} .			

9

End cover screws			Function		
Standard		Stainless steel ²²⁾			
Std scraper	HDPE scraper ²³⁾	FPM scraper	Std scraper	HDPE scraper ²³⁾	FPM scraper
M	D	V	A	H	W
F	E	B	G	Y	Z
2	6	8	—	—	—
C	—	—	—	—	—
Double-acting					
Double-acting through rod					
3 and 4 position cylinders					
Tandem					

16

Factory-fitted piston rod mountings and sealing plugs		
No plugs	With plugs ⁸⁾	
S	A	Swivel rod eye, zinc-plated steel
T	1	Swivel rod eye, stainless steel
V	E	Swivel rod eye, zinc-plated steel and clevis bracket GA
W	2	Swivel rod eye, stainless steel and clevis bracket GA
C	B	Clevis, zinc-plated steel
D	3	Clevis, stainless steel
F	G	Flexo coupling, zinc-plated steel
X	P	One additional piston rod nut ⁹⁾
Y	4	Piston rod nut in stainless steel ¹⁰⁾
Z	5	Piston rod nut in acid-proof steel
6	7	Without piston rod nut
H	L	Rod guidance, H, ball bearings ¹⁸⁾
J	M	Rod guidance, H, plain bearings ¹⁸⁾
K	Q	Rod guidance, U, plain bearings ¹⁸⁾
N	R	None

20-digit order code

16 17 18 19 20

S	N	N	N ¹⁾	N
---	---	---	-----------------	---

17

Cylinder mountings		
90°	0°	90° = shaft square to, 0° = shaft in line with ports ⁵⁾
1	3	Flange MF1/MF2 in front end
B	4	Flange MF1/MF2 in rear end
2	K	Flange MF1/MF2 in both ends
F	–	Foot brackets MS1 (both ends)
C	U	Clevis bracket GA
E	V	Clevis bracket MP4
S	W	Swivel eye bracket
T	Y	Clevis bracket MP2
L	Z	Clevis bracket MP2+MP4
X	5	Clevis bracket MP2+pivot bracket with rigid bearing
Q	0	Clevis bracket GA + pivot bracket with swivel bearing
M	A	Clevis bracket GA +swivel eye bracket
D	6	Centre trunnion MT4, mid position ⁶⁾
G	7	Trunnion MT4, optional pos. (XV-meas. pos 18-20) ⁷⁾
H	P	Trunnion flange in front end
J	8	Trunnion flange in rear end
N		None

18

Factory-fitted sensors			
Front end or left ¹⁾	Rear end or right ¹⁾	Front and rear end	Cable exit
F	R	–	2 sensors 24 VDC pnp, 3 m cable
G	H	–	2 sensors 24 VDC pnp, 10 m cable
C	S	–	2 sensors 24 VDC pnp, 8 mm connector, 1 m cable ²⁾
K	L	–	2 sensors Reed type, 3 m cable
T	V	–	2 sensors Reed type, 10 m cable
M	Q	–	2 sensors Reed type, 8 mm connector, 1 m cable ²⁾
–	–	3	3 sensors 24 VDC pnp, 8 mm connector, 1 m cable ²⁾
–	–	Z	3 sensors Reed type, 8 mm connector, 1 m cable ²⁾
–	–	4	4 sensors 24 VDC pnp, 8 mm connector, 1 m cable ²⁾
–	–	W	4 sensors Reed type, 8 mm connector, 1 m cable ²⁾
6 ¹²⁾	7 ¹³⁾	8 ¹⁴⁾	No factory-fitted sensors P1D Clean
N			No sensors P1D (excl. P1D Clean)

12-13-14-15

Stroke (mm) e.g. 0100 = 100 mm

Optional stroke lengths up to 2800 mm. Standard strokes see table page 14

20

Speed controls or fittings for tube dimension		Valve function	
Speed controls ¹⁷⁾ , Series PTF4PB ¹⁶⁾		Air actuated	
X	in both ends for tube 4 mm ¹⁵⁾	A	Air-Air, 5/2
Y	in both ends for tube 6 mm ¹⁵⁾	B	Air-Spring, 5/2
Z	in both ends for tube 8 mm ¹⁵⁾	C	Air-Air, 5/3, closed centre position
P	in both ends for tube 10 mm ¹⁵⁾	D	Air-Air, 5/3, vented centre
R	in both ends for tube 12 mm ¹⁵⁾	E	Air-Air, 5/3, pressurised centre
Push-in fitting, elbow type for:		Electrically actuated internal supply	
4	Tube dimension 4 mm ¹⁵⁾	F	Elec-Elec, 5/2
6	Tube dimension 6 mm ¹⁵⁾	H	Elec-Spring, 5/2
8	Tube dimension 8 mm ¹⁵⁾	K	Spring-Elec ²⁰⁾ , 5/2
0	Tube dimension 10 mm ¹⁵⁾	M	Elec-Elec, 5/3, closed centre position
2	Tube dimension 12 mm ¹⁵⁾	Q	Elec-Elec, 5/3, vented centre
Push-in fitting, straight type for:		S	Elec-Elec, 5/3, pressurised centre
1	Tube dimension 4 mm ¹⁵⁾	Electrically actuated external supply	
3	Tube dimension 6 mm ¹⁵⁾	G	Elec-Elec, 5/2
5	Tube dimension 8 mm ¹⁵⁾	J	Elec-Spring, 5/2
7	Tube dimension 10 mm ¹⁵⁾	L	Spring-Elec ²⁰⁾ , 5/2
9	Tube dimension 12 mm ¹⁵⁾		
N	None		

19

Piston rod thread

N according to ISO-standard¹⁾

17-18-19-20 4-position cylinders only

Stroke (mm) e.g. 0100 = 100 mm

The longest stroke in a 4 position cylinder. (Total stroke length up to max 2800 mm, see ordering example on page 32)

1-24) Information notes see page 74

Information notes

- 1) Code N for piston rod thread according to the ISO-standard. Other threads on request.
- 2) P1D Clean without sensor function, see page 37.
- 3) Only for P1D-F bore 80-125 mm. Select optional fittings in position 20, see page 38.
- 4) Only for P1D-F bore 32-63 mm. Select fittings in position 20, see page 38.
- 5) Shaft or pivots square to or in line with the cylinder ports.
- 6) For versions P1D-S and P1D-T.
- 7) Only for P1D-T, XV-measure (from the piston rod thread according to ISO to the centre of the pivots) stated in mm in positions 18-20 (max 999).
- 8) Valid only for cylinders with factory-fitted cylinder mountings. P1D Clean cylinders are always delivered with 4 sealing plugs.
- 9) P1D cylinders are always delivered with one piston rod nut in zinc-plated steel, except P1D Clean which is delivered with the piston rod nut in stainless steel. Codes X and P mean that the cylinder is delivered with one additional nut of the same type.
- 10) The piston rod nut in zinc-plated steel is replaced by a nut in stainless steel (P1D Clean is always delivered with one piston rod nut in stainless steel).
- 11) Left and right valid for P1D Standard and P1D Tie-Rod seen from behind with the ports on top. The sensors can only be mounted on the left for P1D Flexible Porting.
- 12) No factory-fitted sensors, but prepared for cable exit in the front end (max. 2 sensors).
- 13) No factory-fitted sensors, but prepared for cable exit in the rear end (max. 2 sensors).
- 14) No factory-fitted sensors, but prepared for cable exit in both ends (max. 4 sensors).
- 15) To choose speed control and fittings, please refer to page 29 for P1D Standard and page 38 for P1D Flexible Porting.
- 16) P1D Clean cylinders have factory installed nickel plated versions of the PTF series.
- 17) Not available with P1D Flexible Porting bore 32-63 mm.
- 18) Valid for bore 32-100 mm.
- 19) Only for piston rod material type C and R.
- 20) Piston in extended position with unactuated valve.
- 21) Due to the sensor positions, the cable length (1 m) could limit the stroke of the P1D Clean cylinders.
- 22) If stainless steel end cover screws are selected, the piston rod nuts are also supplied in stainless steel.
- 23) For dry rod operation.
- 24) The seal system for low pressure hydraulics demands a hard chromed surface for proper function.



Pneumatic Division Sales Offices

Austria - Wr.Neustadt

Tel: +43 2622 23501
Fax: +43 2622 66212

Belgium - Nivelles

Tel: +32 67 280 900
Fax: +32 67 280 999

Czech & Slovak Republics - Prague

Tel: +420 283 085 224
Fax: +420 283 085 360

Denmark - Ballerup

Tel: +45 43 560400
Fax: +45 43 733107

Finland - Vantaa

Tel: +358 9 4767 31
Fax: +358 9 4767 3200

France - Evreux

Tel: +33 820 825 239
Fax: +33 820 029 870

Germany - Kaarst

Tel: +49 2131 4016-0
Fax: +49 2131 4016-9199

Greece - Athens

Tel: +30 210 933 6450
Fax: +30 210 933 6451

Hungary - Budapest

Tel: +36 1 220 4155
Fax: +36 1 422 1525

Italy - Corsico, Milan

Tel: +39 02 4519 21
Fax: +39 02 4479 340

Netherlands - Oldenzaal

Tel: +31 541 585000
Fax: +31 541 585459

Norway - Langhus

Tel: +47 6491 1000
Fax: +47 6491 1090

Poland - Warsaw

Tel: +48 22 863 49 42
Fax: +48 22 863 49 44

Portugal - Leça da Palmeira

Tel: +351 22 999 7360
Fax: +351 22 996 1527

Romania - Bucharest

Tel: +40 21 252 1382
Fax: +40 21 252 3381

Russia - Moscow

Tel: +7 095 234 0054
Fax: +7 095 234 0528

Slovenia - Novo mesto

Tel: +386 7337 6650
Fax: +386 7337 6651

Spain - Madrid

Tel: +34 91 675 7300
Fax: +34 91 675 7711

Sweden - Spånga

Tel: +46 (0) 8 5979 5000
Fax: +46 (0) 8 5979 5120

Switzerland - Biel

Tel: +41 32 3653711
Fax: +41 32 3653730

Turkey - Istanbul

Tel: +90 212 482 91 06
Fax: +90 212 482 91 10

UK - Cannock

Tel: +44 1543 456000
Fax: +44 1543 456001

Ukraine - Kiev

Tel: + 380 44 220 7432
Fax: + 380 44 220 6534

Parker Hannifin plc
Pneumatic Division,
Walkmill Lane, Bridgtown,
Cannock, Staffs. WS11 0LR
United Kingdom

We reserve the right to make
alterations without prior notification.
Edition 05.05

